



**Tecno
Soley**

*Fábrica de parasoles
Parasol manufacturer
Usine de parasols*



*catálogo
catalogue*

EDITION n°

32

2023-2024



INDEX

<i>Parasol de aluminio / Aluminium parasol / Parasol en aluminium</i>	
Serie ESTANDAR	8
Serie ESTANDAR EXTRA	12
Serie ELITE	16
Serie ELITE TELESCOPICO	20
Serie ELITE PLUS	24
Serie ELITE DESPLAZADO	28
Serie PALMA	32
Serie PALMA DESPLAZADO 36	
Serie BERLIN	40
Serie BERLIN DESPLAZADO	44
<i>Parasol de madera / Wood parasol / Parasol en bois</i>	
Serie NATURFUST	6
Serie GOLD EXTRA	48
Serie LUXE	50
Serie CLASSIC	52
Serie NIZA	54
Serie BASIC	56
Serie POOL MADERA	58
<i>Quick service</i>	
Serie POOL	60
Serie SINTRA	61
Serie STREET	62
<i>Accesorios y acabados / Accessories and finishes / Accessoires et finitions</i>	
Bases parasol / Parasol bases / Bases parasols	64
Iluminación / Lighting / Éclairage	70
Calefacción / Heating / Chauffage	74
Fundas parasol / Parasol cases / Housses parasol	75
Cerramientos laterales / Side screens / Bâches latérales	76
Separadores / Fences / Séparateurs	78
Colores estructura / Frame colors / Couleurs monture	68
Estampación textil / Textile printing / Estampage textile	82
Faldón luminoso / Lighting volant / Volant lumineux	83
Tejidos / Fabrics / Tissus	84



Fabricando parasoles desde 1985

37 años de trabajo en constante evolución nos permiten actualmente ofrecer a nuestros clientes una extensa y completa gama de parasoles, que van desde los modelos económicos de importación, hasta los parasoles de fabricación propia, que podemos personalizar a gusto del cliente. Fabricamos nuestras propias monturas, en madera o aluminio, y disponemos de toda clase de tejidos que podemos estampar, siempre, con la premisa de calidad y buenas prestaciones que nos exige nuestro mercado. Nuestro objetivo es encontrar la solución más adecuada a la necesidad del cliente.

Le agradecemos su interés, estamos a su disposición, y no dude en consultarnos.

Manufacturing parasols since 1985

37 years of work in constant evolution allow us to provide our customers with a wide and complete range of parasols, ranging from more affordable import models to manufactured parasols that can be adapted to the customer's taste. We make our own frames in wood or aluminium, and we have all kinds of fabrics that we can print with the sole aim of delivering the quality and good performance that matches our market's needs. Our goal is find the most appropriate solution for our costumers.

Thank you for your interest and we are at your disposal; do not hesitate to contact us.

Fabricant de parasols depuis 1985

37 ans de travail en constante évolution nous permettent d'offrir à nos clients une gamme large et complète de parasols ; l'offre va des modèles économiques d'importation aux parasols de notre propre fabrication qui peuvent être personnalisés au goût du client. Nous fabriquons nos montures en bois ou en aluminium et nous avons toutes sortes de tissus que nous pouvons imprimer, toujours avec un seul objectif : qualité et bonne performance pour l'exigence de notre marché. Notre but est de trouver la solution la plus appropriée au besoin du client.

Nous vous remercions pour votre intérêt. Nous restons à votre disposition, n'hésitez pas à nous contacter.

Nos reservamos el derecho de modificar características técnicas sin previo aviso, sin alterar el funcionamiento del producto.

We reserve the right to modify technical characteristics without prior notice, without altering the functioning of the product.

Nous nous réservons le droit de modifier les caractéristiques techniques sans préavis, sans altérer le fonctionnement du produit.

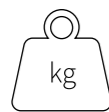

Peso aprox
Approx. weight
Poids approx



Ruedas opcionales
Optional wheels
Roues optionnelles



Volante
Valance
Volant



Caja de conexión
Connection box
Boîte de jonction

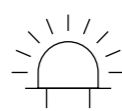

Iluminación LED
LED light
Éclairage LED



Calefacción por infrarrojos
Infrared heater
Chauffage infrarouge

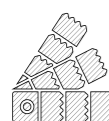

Colores de tejido
Fabric colors
Tissu couleurs

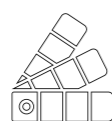

Colores para la montura
Frame colors
Couleurs monture



Imitación madera
Wood imitation
Imitation bois.



Estampado
Printing
Estampage

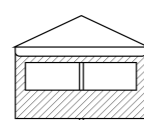

Cerramientos laterales
Side screens
Bâches latérales

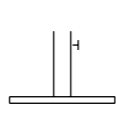

Bases
Bases
Bases

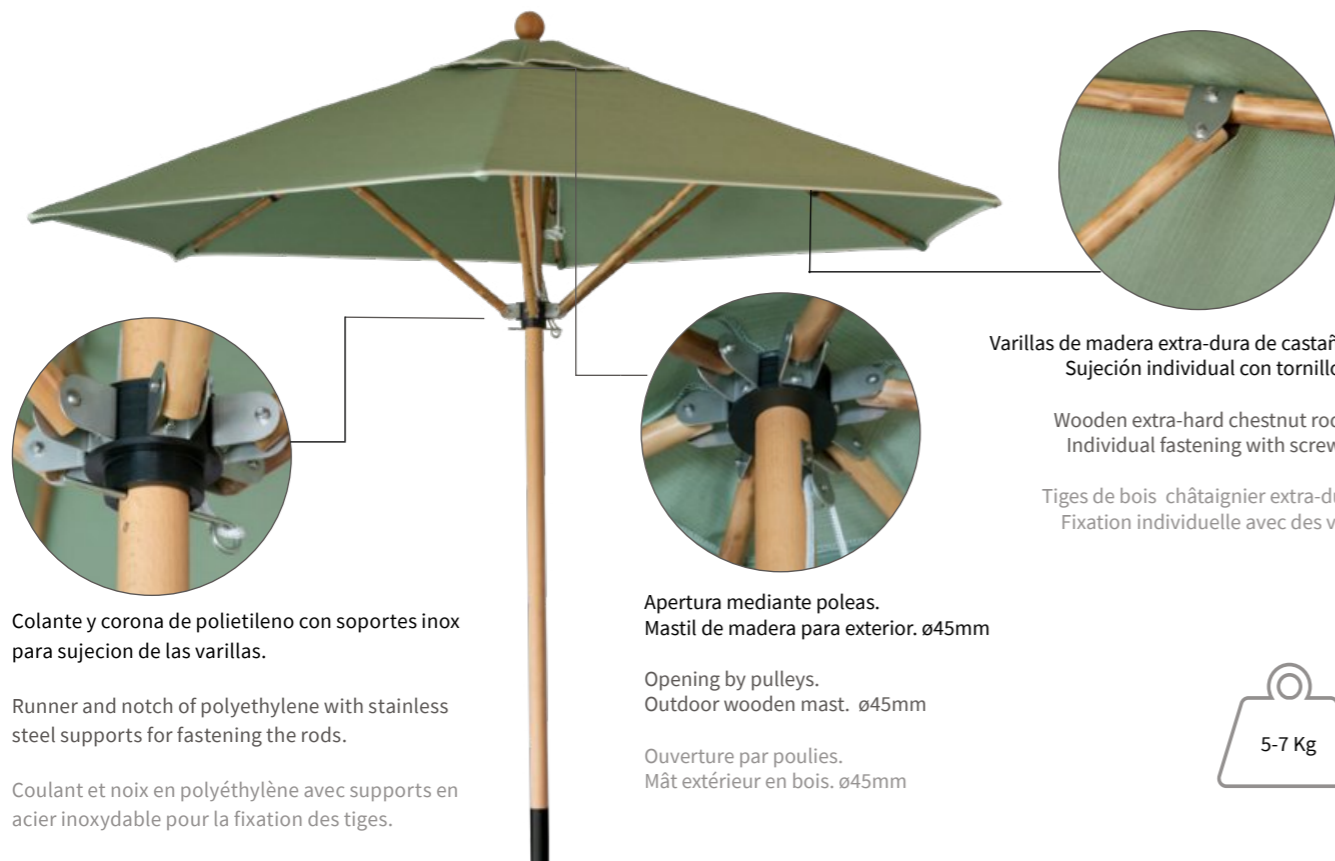

Colante y corona de polietileno con soportes inox para sujeción de las varillas.

Runner and notch of polyethylene with stainless steel supports for fastening the rods.

Coulant et noix en polyéthylène avec supports en acier inoxydable pour la fixation des tiges.

Apertura mediante poleas.
Mastil de madera para exterior. ø45mm

Opening by pulleys.
Outdoor wooden mast. ø45mm

Ouverture par poulies.
Mât extérieur en bois. ø45mm

Varillas de madera extra-dura de castaño.
Sujeción individual con tornillos.

Wooden extra-hard chestnut rods.
Individual fastening with screws.

Tiges de bois châtaignier extra-dur.
Fixation individuelle avec des vis.



5-7 Kg

NOVEDAD 2022

SERIE NATURFUST

Parasol de madera
Wood parasol
Parasol en bois

ES

Varillaje especial de madera de castaño extra dura prácticamente irrompible por uso ordinario. Fabricado artesanalmente, resulta adecuado para hostelería de montaña, terrazas de calles peatonales y jardines particulares, donde se puede apreciar el valor de la elaboración artesanal.

EN

Special extra hard chestnut wood ribs practically unbreakable by ordinary use. Handcrafted, it is suitable for mountain hotels, pedestrian street terraces and private gardens, where you can appreciate the value of craftsmanship.

FR

Baleines en bois de châtaignier extra dur pratiquement incassables par un usage ordinaire. Fabriqué à la main, il convient aux hôtels de montagne, aux terrasses des rues piétonnes et aux jardins privés, où vous pourrez apprécier la valeur de l'artisanat.

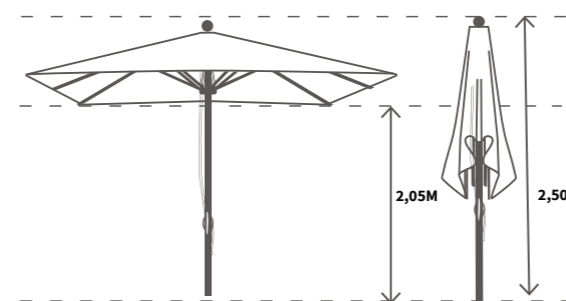

Se presenta con el tejido **FLORIDA**, fabricado con dos hilos de distinto color, formando una estructura flexible y resistente.

It is presented with the **FLORIDA** fabric, made with two threads of different colors, forming a flexible and resistant structure.

Il est présenté avec le tissu **FLORIDA**, composé de deux fils de couleurs différentes, formant une structure souple et résistante.

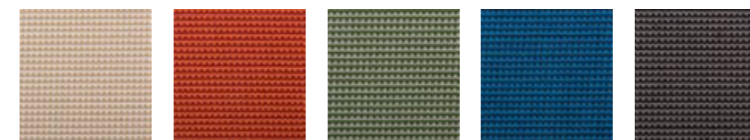

80% protección UV
Teflon
Water repellent

Medidas
Sizes
Measures

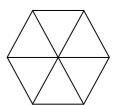

2m / 2,5m / 3m

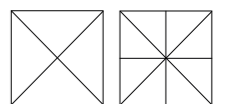

2x2m

2,5x2,5m

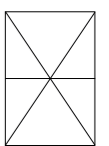

2x2,5m



SERIE ESTANDAR

Parasol de aluminio
Aluminium parasol
Parasol en aluminium

ES

Parasol ligero y de dimensiones reducidas una vez cerrado. Esto permite que sea fácil de manejar y práctico para terrazas que se deben recoger a diario.

EN

Lightweight and compact parasol once closed. This makes it easy to handle for terraces that have to be picked up every day.

FR

Parasol léger et compact une fois fermé. Cela le rend facile à manipuler et pratique pour les terrasses qui doivent ramasser les parasols tous les jours.

Mástil **NORMAL**

Pole **NORMAL**

Mât **NORMAL**

Apertura **POLEAS**

Opening **PULLEYS**

Ouverture **POULIES**

Opciones / Options / Options

Acabados
Finishes
Finitions



ref **TPA/TOP/TAS**
p. 84-87



p.80



p.10



p.82

Accesorios
Accessories
Accessoires

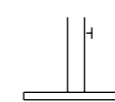

p.64-69

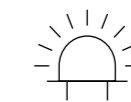

p.70-73

Características / Features / Caractéristiques

SERIE
ESTANDAR

Mástil de aluminio lacado blanco.
Colante y corona de plástico blanco.

White coated aluminium frame.
White plastic runner and notch.

Mât en aluminium laqué blanc.
Coulant et noix en plastique blanc.



Mástil de aluminio anodizado gris.
Colante y corona de plástico gris.

Anodized grey aluminium frame.
Grey plastic runner and notch.

Mât en aluminium anodisé gris.
Coulant et noix en plastique gris.



Mástil de ø50mm (1,5mm de grosor).
Sistema de apertura mediante dos poleas.

ø50mm pole(1,5mm thickness).
Opening system by two pulleys.

Mât ø50mm(1,5mm d'épaisseur).
Système d'ouverture par deux poulies.

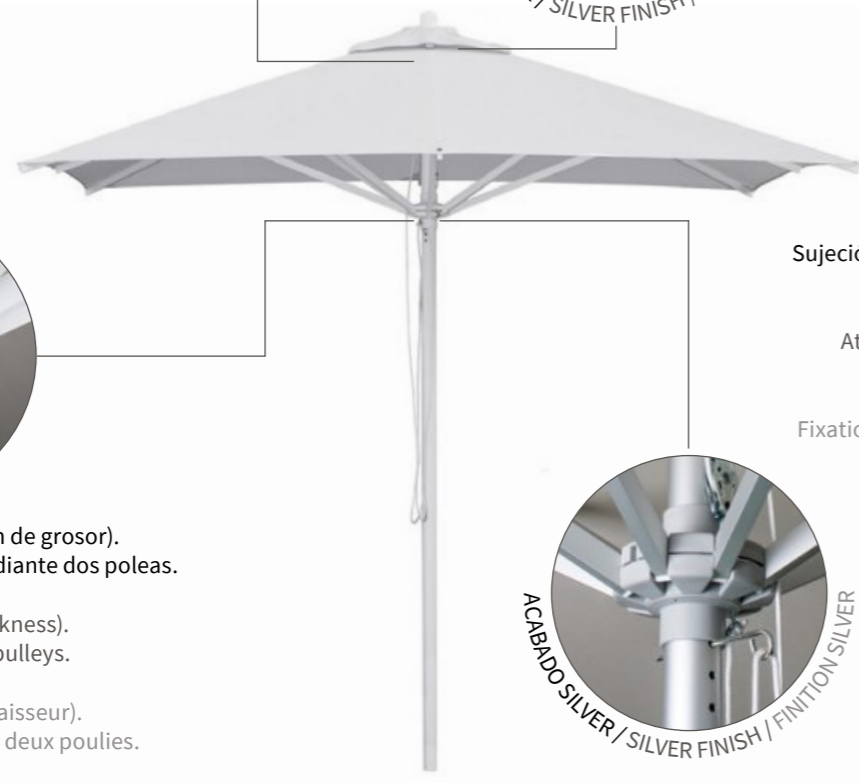

Varillas perfil 15x25 mm.
Sujeción conjunta por alambre.

Section 15x25mm ribs.
Attached together by wire.

Profile 15x25mm.
Fixation conjointe par fil de fer.



Bases recomendadas / Suggested bases / Bases recommandées



Metallica 65-6
Metallic 65-6
Metallique 65-6



Hormigón recubierto y ruedas
Coated concrete and wheels
Béton enduit et roues



Bases para empotrar
Built in bases
Bases à encaster



Fijar 10
Fix 10
Fixer 10

TODAS LAS
BASES /

ALL BASES /

TOUTES
BASES

— p.64

Tabla de medidas / Available sizes / Tableau de mesures

SERIE
ESTANDAR

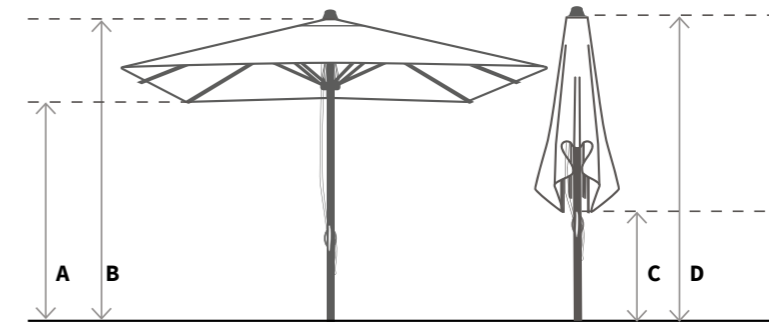

A- Altura varilla abierto
Rib height open
Hauteur baleine ouvert

B- Altura parasol abierto
Open parasol height
Hauteur parasol ouvert

C- Altura varilla cerrado
Rib height closed
Hauteur baleine fermé

D- Altura parasol cerrado
Closed parasol height
Hauteur parasol fermé

forma shape forme	medida measurement dimension	varillas ribs baleines	mástil pole mât	altura A height A hauteur A	altura B height B hauteur B	altura C height C hauteur C	altura D height D hauteur D	embalaje packaging emballage
	2m	8	Ø50mm	186cm	242cm	136cm	242cm	23x23x245cm
	2'4m	8	Ø50mm	196cm	250cm	124cm	250cm	23x23x250cm
	3m	8	Ø50mm	190cm	250cm	93cm	250cm	23x23x250cm
	3'5m	8	Ø50mm	187cm	250cm	69cm	250cm	23x23x250cm
	4m	8	Ø50mm	219cm	275cm	69cm	275cm	23x23x275cm

	2x2m	8	Ø50mm	210cm	250cm	118cm	250cm	23x23x250cm
	2'4x2'4m	8	Ø50mm	208cm	250cm	76cm	250cm	23x23x250cm
	2'5x2'5m	8	Ø50mm	218cm	275cm	90cm	275cm	23x23x275cm
	3x3m	8	Ø50mm	222cm	275cm	58cm	275cm	23x23x275cm

	2x2'5m	8	Ø50mm	194cm	250cm	81cm	250cm	23x23x250cm
	2x3m	8	Ø50mm	195cm	250cm	64cm	250cm	23x23x250cm
	2,5x3m	8	Ø50mm	206cm	275cm	69cm	275cm	23x23x275cm



SERIE ESTANDAR EXTRA

Parasol de aluminio
Aluminium parasol
Parasol en aluminium

ES

Parasol pequeño pero con la resistencia de los modelos de gama superior. Este parasol, una vez cerrado, tiene unas dimensiones reducidas que permiten almacenarlo en espacios pequeños. Gracias a su robustez y las opciones de PVC y cerramientos se convierte en un parasol ideal para zonas con un clima irregular.

EN

Small parasol with the same resistance as the larger model. When closed, this parasol's compact dimensions make it storable in small spaces. This product is ideal for areas with unstable climate thanks to its robustness. Side-screens and PVC options available.

FR

Petit parasol avec la résistance des grands modèles. Ce parasol, une fois fermé, a des dimensions qui permettent le ranger dans de petits espaces. Grâce à sa robustesse il devient un parasol idéal pour les zones à climat irrégulier. Options de PVC et bâches latérales disponibles.

Mástil **NORMAL**

Pole **NORMAL**

Mât **NORMAL**

Apertura **POLEAS**

Opening **PULLEYS**

Ouverture **POULIES**

Opciones / Options / Options

Acabados
Finishes
Finitions

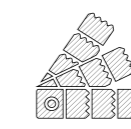

ref. **TOP/TAS/TPS**
p. 84-87



p.80



p.81



p.82

Accesorios
Accessories
Accessoires

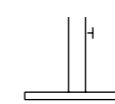

p.64-69

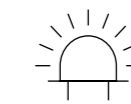

p.70-73



p.72



p.74

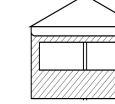

p.76

Características / Features / Caractéristiques

SERIE
ESTANDAR EXTRA

Mástil de aluminio lacado blanco
Colante y corona de aluminio

White coated aluminium pole
Aluminium runner and notch

Mât Aluminium laqué blanc
Coulant et noix en aluminium



Mástil de Ø50mm (3mm de espesor).
Sistema apertura mediante dos juegos
de poleas dobles.

Ø50mm pole (3mm thickness).
Opening system by two pulleys.

Mât Ø50mm (3mm d'épaisseur).
Système d'ouverture par deux poulies.



Varillas perfil 20x30mm.
Sujeción individual
mediante tornillos.

Section 20x30mm ribs.
Attached individually
by screws.

Profile 20x30mm.
Fixation individuelle
par vis.



Bases recomendadas / Suggested bases / Bases recommandées



Fijar 20
Fijar 20
Fixer 20



Metalica 65
Metallic 65
Metallique 65



Bases para empotrar
Built in bases
Bases à encaster



Resinada rellenable
Refill resined
Résine Rechargeable

TODAS LAS
BASES /

ALL BASES /

TOUTES
BASES

— p.64

Tabla de medidas / Available sizes / Tableau de mesures

SERIE
ESTANDAR EXTRA

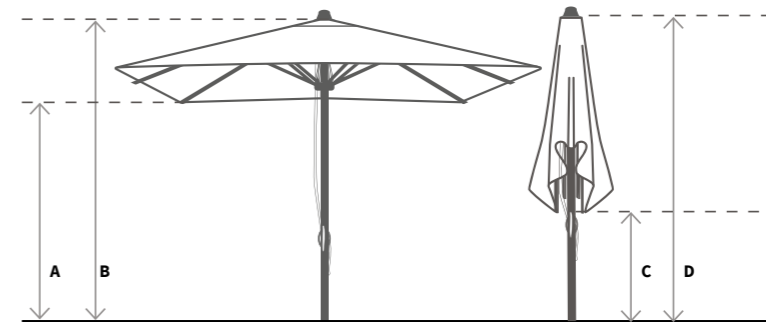

A- Altura varilla abierto
Rib height open
Hauteur baleine ouvert

B- Altura parasol abierto
Open parasol height
Hauteur parasol ouvert

C- Altura varilla cerrado
Rib height closed
Hauteur baleine fermé

D- Altura parasol cerrado
Closed parasol height
Hauteur parasol fermé

forma shape forme	medida measurement dimension	varillas ribs baleines	mástil pole mât	altura A height A hauteur A	altura B height B hauteur B	altura C height C hauteur C	altura D height D hauteur D	embalaje packaging emballage
	3m	8	Ø50mm	225cm	287cm	130cm	287cm	40x40x290cm
	3,5m	8	Ø50mm	225cm	297cm	113cm	297cm	40x40x300cm
	4m	8	Ø50mm	225cm	280cm	79cm	280cm	40x40x283cm
	2x2m	8	Ø50mm	225cm	271cm	128cm	271cm	40x40x274cm
	2'5x2'5m	8	Ø50mm	225cm	294cm	112cm	294cm	40x40x297cm
	3x3m	8	Ø50mm	225cm	285cm	69cm	285cm	40x40x288cm
	3'5x3'5m	8	Ø50mm	225cm	294cm	43cm	294cm	40x40x297cm
	2x2'5m	8	Ø50mm	194cm	250cm	81cm	250cm	23x23x250cm
	2x3m	8	Ø50mm	195cm	250cm	64cm	250cm	23x23x250cm
	2,5x3m	8	Ø50mm	206cm	275cm	69cm	275cm	23x23x275cm
	2,5x3m	8	Ø50mm	225cm	277cm	81cm	277cm	40x40x280cm
	2'5x3'5m	8	Ø50mm	225cm	283cm	67cm	283cm	40x40x286cm
	3x3'5m	8	Ø50mm	225cm	276cm	46cm	276cm	40x40x279cm



SERIE ELITE

Parasol de aluminio Aluminium parasol Parasol en aluminium

ES

Parasol más económico dentro de la gama de mástiles de 70mm. Gracias a su amplio abanico de medidas se pueden crear tanto pequeñas como grandes instalaciones. A diferencia de los modelos telescópicos, la apertura mediante poleas permite su uso y almacenaje en espacios de altura reducida. Es un parasol destinado a la hostelería.

EN

More affordable parasol among the 70mm pole range. Thanks to its wide array of sizes, both small and large installations can be created. Unlike the telescopic ones, its pulley opening makes it usable and storable in spaces with low headroom. It is a parasol designed for the hotel and catering industry.

FR

Un parasol plus économique dans la gamme des mâts de 70mm. Grâce à sa large palette de dimensions, il est possible de réaliser des installations de petite et de grande taille. Contrairement aux télescopiques, son ouverture par poulies permet son utilisation et stockage dans des espaces de hauteur réduite. C'est un parasol destiné à l'hôtellerie et à la restauration.

Mástil **NORMAL**

Pole **NORMAL**

Mât **NORMAL**

Apertura **POLEAS**

Opening **PULLEYS**

Ouverture **POULIES**

Opciones / Options / Options

Acabados
Finishes
Finitions

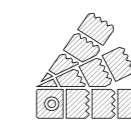

ref. **TOP/TAS/TPS**
p. 84-87



p.80

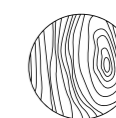

p.81



p.82

Accesorios
Accessories
Accessoires

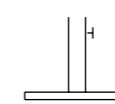

p.64-69

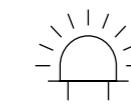

p.70-73



p.72



p.74

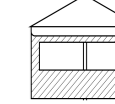

p.76

Características / Features / Caractéristiques

SERIE
ELITE

Mástil de aluminio lacado blanco
Colante y corona de aluminio

White coated aluminium pole
Aluminium runner and notch

Mât en aluminium laqué blanc
Coulant et noix en aluminium



Mástil de Ø70mm
Sistema apertura mediante dos juegos
de poleas dobles.

Ø70mm pole
Opening system by two pulleys.

Mât Ø70mm
Système d'ouverture par deux poulies.



Varillas perfil 20x40mm.
Sujeción individual
mediante tornillos.

Section 20x40mm ribs.
Attached individually
by screws.

Profile 20x40mm.
Fixation individuelle
par vis.



Bases recomendadas / Suggested bases / Bases recommandées



Fijar 20
Fix 20
Fixar 20



Metalica 65
Metallic 65
Metallique 65



Base de baldosas
Tiles base
Base delles



Bases para empotrar
Built in bases
Bases à encastrer

TODAS LAS
BASES /
ALL BASES /
TOUTES
BASES

— p.64

Tabla de medidas / Available sizes / Tableau de mesures

SERIE
ELITE

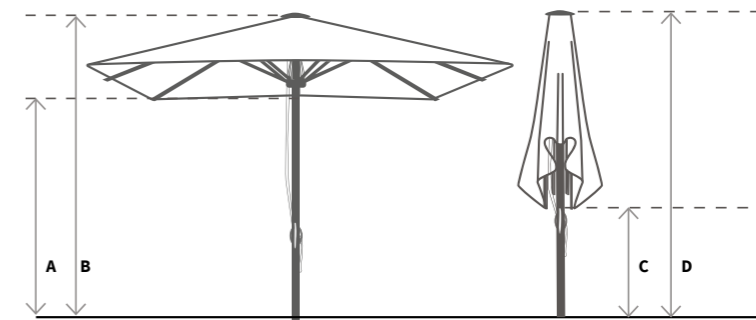

A- Altura varilla abierto
Rib height open
Hauteur baleine ouvert

B- Altura parasol abierto
Open parasol height
Hauteur parasol ouvert

C- Altura varilla cerrado
Rib height closed
Hauteur baleine fermé

D- Altura parasol cerrado
Closed parasol height
Hauteur parasol fermé

forma shape forme	medida measurement dimension	varillas ribs baleines	mástil pole mât	altura A height A hauteur A	altura B height B hauteur B	altura C height C hauteur C	altura D height D hauteur D	embalaje packaging emballage
	3m	8	Ø70mm	225cm	287cm	130cm	287cm	40x40x290cm
	3,5m	8	Ø70mm	225cm	297cm	113cm	297cm	40x40x300cm
	4m	8	Ø70mm	225cm	280cm	79cm	280cm	40x40x283cm
	2X2m	8	Ø70mm	225cm	271cm	128cm	271cm	40x40x274cm
	2'5x2'5m	8	Ø70mm	225cm	294cm	112cm	294cm	40x40x297cm
	3x3m	8	Ø70mm	225cm	285cm	69cm	285cm	40x40x288cm
	3'5x3'5m	8	Ø70mm	225cm	294cm	43cm	294cm	40x40x297cm
	4x4m	8	Ø70mm	225cm	309cm	20cm	309cm	40x40x312cm
	2x2'5m	8	Ø70mm	225cm	273cm	114cm	273cm	40x40x276cm
	2x3m	8	Ø70mm	225cm	268cm	91cm	268cm	40x40x271cm
	2x3,5m	8	Ø70mm	225cm	261cm	63cm	261cm	40x40x264cm
	2,5x3m	8	Ø70mm	225cm	277cm	81cm	277cm	40x40x280cm
	2'5x3'5m	8	Ø70mm	225cm	283cm	67cm	283cm	40x40x286cm
	3x3'5m	8	Ø70mm	225cm	276cm	46cm	276cm	40x40x279cm
	3x4m	8	Ø70mm	225cm	294cm	41cm	294cm	40x40x297cm
	3,5x4m	8	Ø70mm	225cm	322cm	47cm	322cm	40x40x325cm



SERIE ELITE TELESCÓPICO

Parasol de aluminio
Aluminium parasol
Parasol en aluminium

ES

Parasol fuerte y resistente. Destaca por un sistema de apertura telescópica con varilla que permite cerrar el parasol sin necesidad de apartar mesas, sillas o el mobiliario situado debajo. Es un parasol destinado a la hostelería.

EN

Strong and resistant parasol. It stands due to its telescopic opening system with a tick allowing the parasol to be closed without removing the furniture underneath. It is a model designed for the hotel and catering industry.

FR

Parasol solide et résistant. Il se distingue par son système d'ouverture télescopique avec une tige qui permet de fermer le parasol sans enlever les meubles en dessous. C'est un parasol destiné à l'hôtellerie et à la restauration.

Mástil **TELESCÓPICO** Apertura **SEMI-AUTO con varilla manual**
Pole **TELESCOPIC** Opening **SEMI-AUTO push and pull**
Mât **TÉLESCOPIQUE** Ouverture **SEMI-AUTO avec tige manuelle**

Opciones / Options / Options

Acabados
Finishes
Finitions

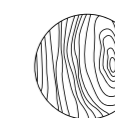
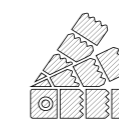

ref. **TAS/TPS**
p. 84-87

p.80

p.81

p.82

Accesorios
Accessories
Accessoires

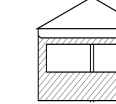
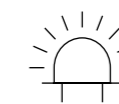
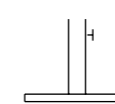

p.64-69

p.70-73

p.72

p.74

p.76

Características / Features / Caractéristiques

SERIE
ELITE TELESCÓPICO

Colante y corona de aluminio y/o polietileno con soporte inox para las varillas.

Aluminium and/or polyethylene runner and notch with inox brackets for ribs.

Coulant et noix en aluminium et/ou polyéthylène avec support de baleine en inox.



Varillas perfil 20x40mm.
Sujeción individual mediante tornillos.

Section 20x40mm ribs.
Attached individually by screws.

Profile 20x40mm.
Fixation individuelle par vis.

Mástil de $\varnothing 70$ mm.
Sistema apertura telescópico mediante varilla manual.

$\varnothing 70$ mm pole.
Telescopic opening system with manual tick.

Mât $\varnothing 70$ mm.
Système d'ouverture télescopique avec tige manuelle.



Bases recomendadas / Suggested bases / Bases recommandées



Fijar 20
Fix 20
Fixar 20



Metalica 65
Metallic 65
Metalique 65



Base jardinera
Planter base
Base jardinière



Tapa abatible
Base with lid
Couvercle rabattable

TODAS LAS BASES /

ALL BASES /

TOUTES BASES

— p.64

Tabla de medidas / Available sizes / Tableau de mesures

SERIE
ELITE TELESCÓPICO

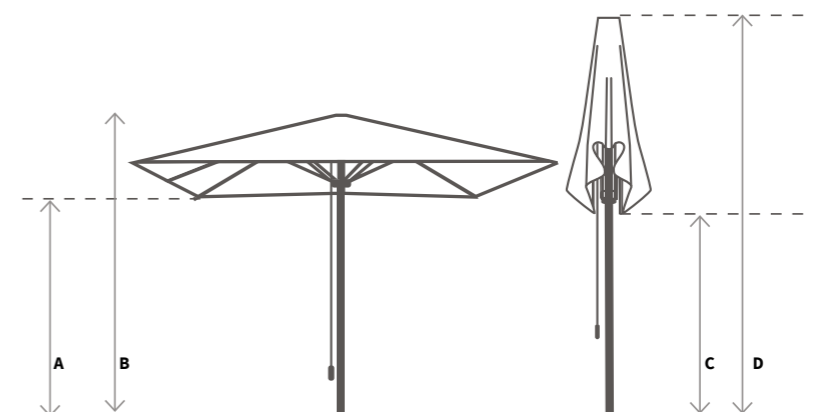



A- Altura varilla abierto
Rib height open
Hauteur baleine ouvert

B- Altura parasol abierto
Open parasol height
Hauteur parasol ouvert

C- Altura varilla cerrado
Rib height closed
Hauteur baleine fermé

D- Altura parasol cerrado
Closed parasol height
Hauteur parasol fermé

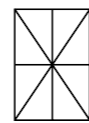
forma shape forme	medida measurement dimension	varillas ribs baleines	mástil pole mât	altura A height A hauteur A	altura B height B hauteur B	altura C height C hauteur C	altura D height D hauteur D	embalaje packaging emballage
	3m	8	$\varnothing 70$ mm	225cm	287cm	182cm	340cm	40x40x343cm
	3'5m	8	$\varnothing 70$ mm	225cm	297cm	166cm	350cm	40x40x353cm
	4m	8	$\varnothing 70$ mm	225cm	281cm	168cm	370cm	40x40x373cm
	5m	8	$\varnothing 70$ mm	225cm	316cm	166cm	426cm	40x40x429cm
	2x2m	8	$\varnothing 70$ mm	225cm	271cm	204cm	347cm	40x40x350cm
	2'5x2'5m	8	$\varnothing 70$ mm	225cm	285cm	185cm	367cm	40x40x370cm
	3x3m	8	$\varnothing 70$ mm	225cm	287cm	152cm	368cm	40x40x371cm
	3'5x3'5m	8	$\varnothing 70$ mm	225cm	294cm	144cm	395cm	40x40x398cm
	4x4m	8	$\varnothing 70$ mm	225cm	311cm	112cm	400cm	40x40x403cm
	4,5x4,5m	8	$\varnothing 70$ mm	225cm	310cm	98cm	423cm	40x40x426cm
	2x2'5m	8	$\varnothing 70$ mm	225cm	273cm	209cm	369cm	40x40x372cm
	2x3m	8	$\varnothing 70$ mm	225cm	270cm	193cm	372cm	40x40x375cm
	2x3'5m	8	$\varnothing 70$ mm	225cm	263cm	167cm	365cm	40x40x368cm
	2x4m	8	$\varnothing 70$ mm	225cm	275cm	140cm	363cm	40x40x366cm
	2'5x3m	8	$\varnothing 70$ mm	225cm	277cm	151cm	346cm	40x40x349cm
	2'5x3'5m	8	$\varnothing 70$ mm	225cm	283cm	185cm	400cm	40x40x403cm
	2'5x4m	8	$\varnothing 70$ mm	225cm	273cm	154cm	388cm	40x40x491cm
	2'5x4'5m	8	$\varnothing 70$ mm	225cm	289cm	104cm	362cm	40x40x365cm
	3x3'5m	8	$\varnothing 70$ mm	225cm	276cm	167cm	395cm	40x40x398cm
	3x4m	8	$\varnothing 70$ mm	225cm	295cm	142cm	395cm	40x40x398cm
	3x4'5m	8	$\varnothing 70$ mm	225cm	292cm	100cm	372cm	40x40x375cm
	3'5x4m	8	$\varnothing 70$ mm	225cm	322cm	177cm	440cm	40x40x443cm
	3'5x4'5m	8	$\varnothing 70$ mm	225cm	305cm	110cm	399cm	40x40x402cm
	4x4,5m	8	$\varnothing 70$ mm	225cm	319cm	105cm	414cm	40x40x417cm



SERIE ELITE PLUS

Parasol de aluminio
Aluminium parasol
Parasol en aluminium

ES

Parasol de gran resistencia y dimensiones. Es el único de la gama Elite con apertura telescópica mediante manivela y usillo

EN

Parasol offering great resistance and size. This parasol is the only one in the Elite range with a crank telescopic opening.

FR

Parasol de grande résistance et dimensions. C'est le seul parasol de la gamme Elite à avoir une ouverture télescopique par manivelle avec vis-sans-fin.

Mástil **TELESCÓPICO**

Pole **TELESCOPIC**

Mât **TÉLESCOPIQUE**

Apertura **MANIVELA con usillo**

Opening **CRANK with endless screw**

Ouverture **MANIVELLE avec vis sans fin**

Opciones / Options / Options

Acabados
Finishes
Finitions

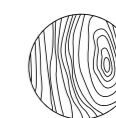
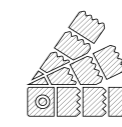

ref. **TAS/TPS**
p. 84-87

p.80

p.81

p.82

Accesorios
Accessories
Accessoires

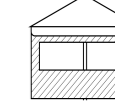
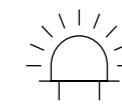
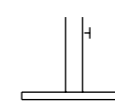

p.64-69

p.70-73

p.72

p.74

p.76

Características / Features / Caractéristiques

SERIE
ELITE PLUS

Colante y corona de aluminio y/o polietileno con soporte inox para las varillas.

Aluminium and/or polyethylene runner and notch with inox brackets for ribs.

Coulant et noix en aluminium et/ou polyéthylène avec support de baleine en inox.

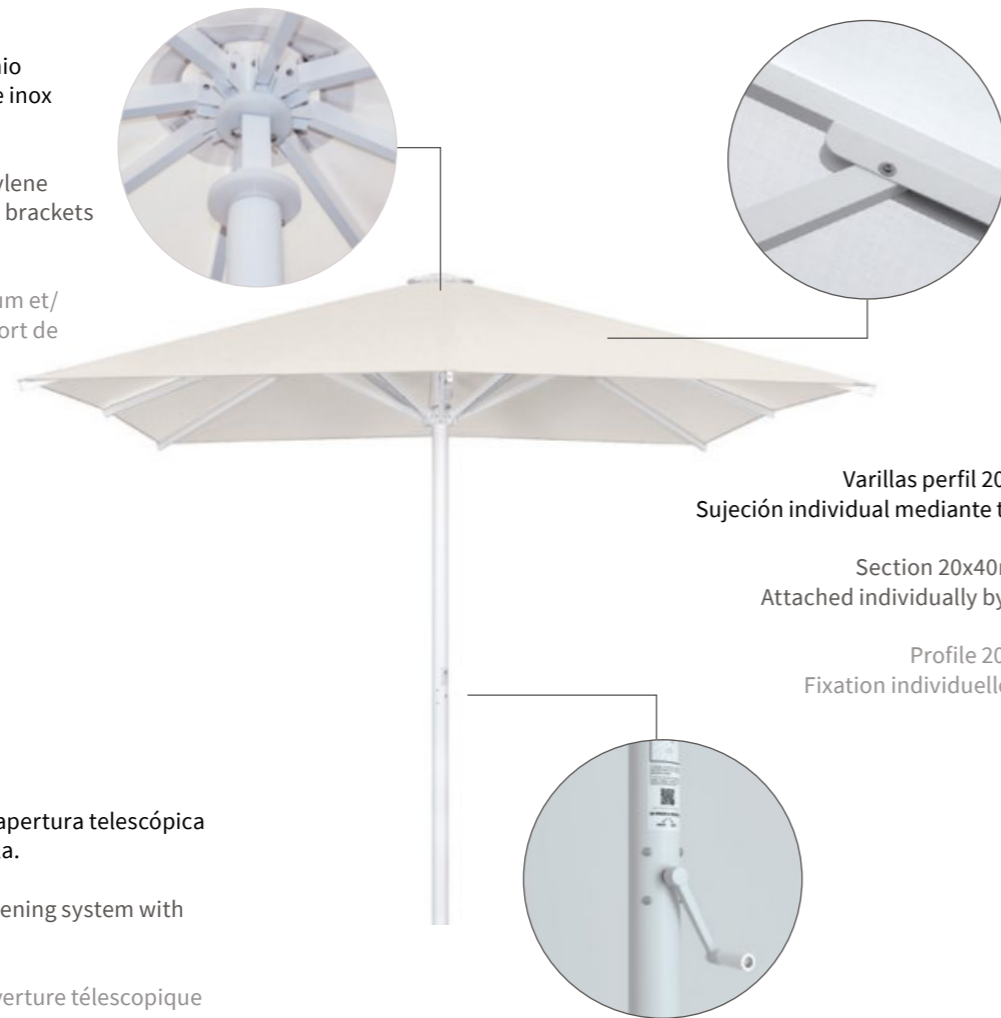

Varillas perfil 20x40mm.
Sujeción individual mediante tornillos.

Section 20x40mm ribs.
Attached individually by screws.

Profile 20x40mm.
Fixation individuelle par vis.

Mástil de \varnothing 70mm. Sistema apertura telescópica con mecanismo de manivela.

\varnothing 70mm pole. Telescopic opening system with manual crank.

Mât \varnothing 70mm. Système d'ouverture télescopique avec manivelle manuelle.



Bases recomendadas / Suggested bases / Bases recommandées



Fijar 20
Fix 20
Fixar 20



Metalica 65
Metallic 65
Metalique 65



Base jardinera
Planter base
Base jardinière



Tapa abatible
Base with lid
Couvercle rabattable

TODAS LAS
BASES /
ALL BASES /
TOUTES
BASES

— p.64

Tabla de medidas / Available sizes / Tableau de mesures

SERIE
ELITE PLUS

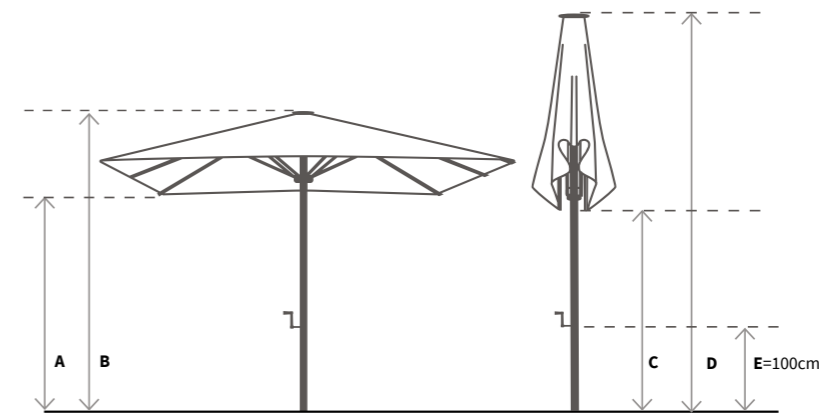



A- Altura varilla abierto
Rib height open
Hauteur baleine ouvert

B- Altura parasol abierto
Open parasol height
Hauteur parasol ouvert

C- Altura varilla cerrado
Rib height closed
Hauteur baleine fermé

D- Altura parasol cerrado
Closed parasol height
Hauteur parasol fermé

E - Altura manivela
Crank height
Hauteur manivelle

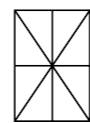
forma shape forme	medida measurement dimension	varillas ribs baleines	mástil pole mât	altura A height A hauteur A	altura B height B hauteur B	altura C height C hauteur C	altura D height D hauteur D	embalaje packaging emballage
	3m	8	\varnothing 70mm	225cm	287cm	182cm	340cm	40x40x343cm
	3'5m	8	\varnothing 70mm	225cm	297cm	166cm	350cm	40x40x353cm
	4m	8	\varnothing 70mm	225cm	281cm	168cm	370cm	40x40x373cm
	5m	8	\varnothing 70mm	225cm	316cm	166cm	426cm	40x40x429cm
	2x2m	8	\varnothing 70mm	225cm	271cm	204cm	347cm	40x40x350cm
	2'5x2'5m	8	\varnothing 70mm	225cm	285cm	185cm	367cm	40x40x370cm
	3x3m	8	\varnothing 70mm	225cm	287cm	152cm	368cm	40x40x371cm
	3'5x3'5m	8	\varnothing 70mm	225cm	294cm	144cm	395cm	40x40x398cm
	4x4m	8	\varnothing 70mm	225cm	311cm	112cm	400cm	40x40x403cm
	4,5x4,5m	8	\varnothing 70mm	225cm	310cm	98cm	423cm	40x40x426cm
	2x2'5m	8	\varnothing 70mm	225cm	273cm	209cm	369cm	40x40x372cm
	2x3m	8	\varnothing 70mm	225cm	270cm	193cm	372cm	40x40x375cm
	2x3'5m	8	\varnothing 70mm	225cm	263cm	167cm	365cm	40x40x368cm
	2x4m	8	\varnothing 70mm	225cm	275cm	140cm	363cm	40x40x366cm
	2'5x3m	8	\varnothing 70mm	225cm	277cm	151cm	346cm	40x40x349cm
	2'5x3'5m	8	\varnothing 70mm	225cm	283cm	185cm	400cm	40x40x403cm
	2'5x4m	8	\varnothing 70mm	225cm	273cm	154cm	388cm	40x40x491cm
	2'5x4'5m	8	\varnothing 70mm	225cm	289cm	104cm	362cm	40x40x365cm
	3x3'5m	8	\varnothing 70mm	225cm	276cm	167cm	395cm	40x40x398cm
	3x4m	8	\varnothing 70mm	225cm	295cm	142cm	395cm	40x40x398cm
	3x4'5m	8	\varnothing 70mm	225cm	292cm	100cm	372cm	40x40x375cm
	3'5x4m	8	\varnothing 70mm	225cm	322cm	177cm	440cm	40x40x443cm
	3'5x4'5m	8	\varnothing 70mm	225cm	305cm	110cm	399cm	40x40x402cm
	4x4,5m	8	\varnothing 70mm	225cm	319cm	105cm	414cm	40x40x417cm



SERIE ELITE DESPLAZADO

Parasol de aluminio
Aluminium parasol
Parasol en aluminium

ES

Parasol de la colección Elite con la particularidad que tiene el mástil desplazado del eje central, situado a 50cm del lateral y apertura telescópica. Ideal para terrazas con un espacio estrecho. Junto con los complementos de cerramientos laterales y canaletas permite crear espacios íntimos sin la molestia de un mástil en medio.

EN

Parasol from the Elite collection with a special feature: its pole is shifted from the central axis and located 50cm from the side and telescopic opening. It is ideal for narrow terraces. By adding side screens and gutters it allows for intimate spaces without the inconvenience of a central pole.

FR





Parasol de la collection Elite avec la particularité d'avoir le mât déplacé par rapport à l'axe central, situé à 50cm du côté et ouverture télescopique.. Idéal pour des terrasses étroites. Avec des bâches latérales et des gouttières, il permet de créer des espaces intimes sans les inconvénients d'un mât central.

Mástil **TELESCÓPICO** Apertura **SEMI-AUTO con varilla manual**

Pole **TELESCOPIC** Opening **SEMI-AUTO push and pull**

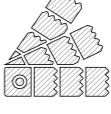
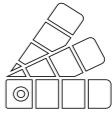
Mât **TÉLESCOPIQUE** Ouverture **SEMI-AUTO avec tige manuelle**

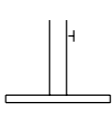
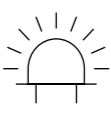
Opciones / Options / Options

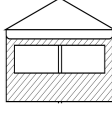
Acabados Finishes Finitions		 ref. TAS/TPS p. 84-87	 p.80	 p.81	 p.82
Accesorios Accessories Accessoires	 p.64-69	 p.70-73	 p.72	 p.74	 p.76

Características / Features / Caractéristiques

SERIE
ELITE DESPLAZADO

Colante y corona de aluminio y/o polietileno con soporte inox para las varillas.

Aluminium and/or polyethylene runner and notch with inox brackets for ribs.

Coulant et noix en aluminium et/ou polyéthylène avec support de baleine en inox.



Mástil de $\varnothing 70$ mm. Sistema apertura telescópico con varilla manual.

$\varnothing 70$ mm pole. Telescopic opening system with manual tick.

Mât $\varnothing 70$ mm. Système d'ouverture télescopique avec tige manuelle.



Varillas perfil 20x40mm. Sujeción individual mediante tornillos.

Section ribs 20x40mm. Attached individually by screws.

Baleines profile 20x40mm. Fixation individuelle par vis.

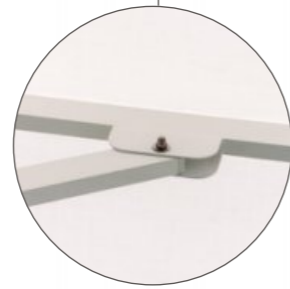

Bases recomendadas / Suggested bases / Bases recommandées



Fijar 20
Fix 20
Fixar 20



Base de baldosas
Tiles base
Base delles



Base jardinera
Planter base
Base jardinière



Bases para empotrar
Built in bases
Bases à encaster

TODAS LAS BASES /
ALL BASES /
TOUTES BASES

— p.64

Tabla de medidas / Available sizes / Tableau de mesures

SERIE
ELITE DESPLAZADO

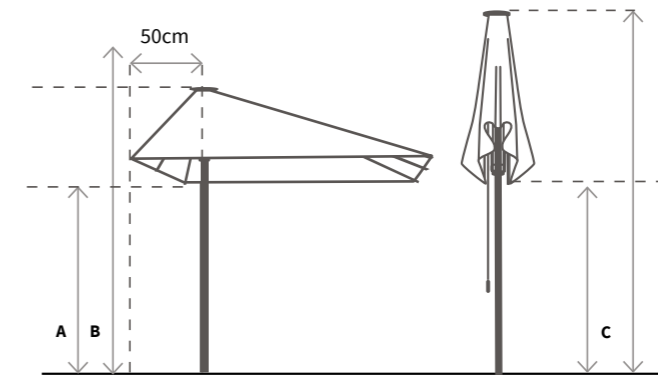

A- Altura varilla abierto
Rib height open
Hauteur baleine ouvert

B- Altura parasol abierto
Open parasol height
Hauteur parasol ouvert

C- Altura varilla cerrado
Rib height closed
Hauteur baleine fermé

D- Altura parasol cerrado
Closed parasol height
Hauteur parasol fermé

forma shape forme	medida measurement dimension	varillas ribs baleines	mástil pole mât	altura A height A hauteur A	altura B height B hauteur B	altura C height C hauteur C	altura D height D hauteur D	embalaje packaging emballage
	2x2m	6	$\varnothing 70$ mm	225cm	271cm	186cm	365cm	40x40x368cm
	2'5x2'5m	6	$\varnothing 70$ mm	225cm	285cm	185cm	367cm	40x40x368cm
	1,5x2m	6	$\varnothing 70$ mm	225cm	273cm	215cm	357cm	40x40x360cm
	1,5x2,5m	6	$\varnothing 70$ mm	225cm	280cm	165cm	365cm	40x40x368cm
	1,5x3m	6	$\varnothing 70$ mm	225cm	285cm	185cm	368cm	40x40x371cm
	1,5x3,5m	6	$\varnothing 70$ mm	225cm	293cm	162cm	369cm	40x40x372cm
	2x2'5m	6	$\varnothing 70$ mm	225cm	271cm	171cm	365cm	40x40x368cm
	2x3m	6	$\varnothing 70$ mm	225cm	271cm	129cm	381cm	40x40x384cm
	2x3'5m	6	$\varnothing 70$ mm	225cm	282cm	146cm	377cm	40x40x380cm
	2x4m	6	$\varnothing 70$ mm	225cm	277cm	132cm	380cm	40x40x383cm
	2x4'5m	6	$\varnothing 70$ mm	225cm	283cm	123cm	393cm	40x40x396cm
	2'5x2m	6	$\varnothing 70$ mm	225cm	280cm	147cm	375cm	40x40x378cm
	2'5x3m	6	$\varnothing 70$ mm	225cm	279cm	152cm	400cm	40x40x403cm
	2'5x3'5m	6	$\varnothing 70$ mm	225cm	287cm	144cm	410cm	40x40x413cm
	2'5x4m	6	$\varnothing 70$ mm	225cm	294cm	134cm	419cm	40x40x421cm
2'5x4'5m	6	$\varnothing 70$ mm	225cm	302cm	106cm	410cm	40x40x413cm	



SERIE PALMA

Parasol de aluminio
Aluminium parasol
Parasol en aluminium

ES

Parasol que se fabrica en diversas medidas y de grandes dimensiones, gracias a su estructura con un resistente mastil de 90mm de diametro. Es un parasol fuerte y robusto ideal para medianas y grandes intalaciones.

EN

Parasol allowing for the largest dimensions and most varied sizes in our collection thanks to its sturdy 90mm diameter pole. Its crank makes it easier to open up. It is a strong and robust parasol that is for medium to large installations.

FR

Parasol qui permet les plus grandes dimensions et les mesures les plus diverses dans notre collection grâce à son mât résistant de 90mm de diamètre. Sa manivelle permet de l'ouvrir facilement. C'est un parasol solide et robuste, idéal pour des installations de taille moyenne à grande.

Mástil **TELESCÓPICO** Apertura **MANIVELA con usillo**
Pole **TELESCOPIC** Opening **CRANK with endless screw**
Mât **TÉLESCOPIQUE** Ouverture **MANIVELLE avec vis sans fin**

Opciones / Options / Options

Acabados
Finishes
Finitions

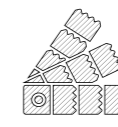

ref. **TAS/TPS**
p. 84-87



p.80

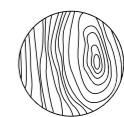

p.81



p.82

Accesorios
Accessories
Accessoires

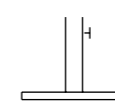

p.64-69

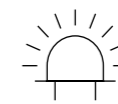

p.70-73



p.72



p.74

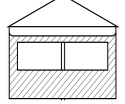

p.76

Características / Features / Caractéristiques

SERIE
PALMA

Colante y corona de aluminio y/o polietileno con soporte inox para las varillas.

Aluminium and/or polyethylene runner and notch with inox brackets for ribs.

Coulant et noix en aluminium et/ou polyéthylène avec support de baleine en inox.



Varillas perfil 20x40mm.
Sujeción individual mediante tornillos.

Section 20x40mm ribs.
Attached individually by screws.

Profile 20x40mm.
Fixation individuelle par vis.

Mástil de ø90cm. Estructura de aluminio lacado blanco. Sistema telescópico con manivela.

90cm pole. White coated aluminium frame. Telescopic opening system with crank.

Mât de ø90mm. Monture en aluminium laqué blanc. Système télescopique avec manivelle.



Bases recomendadas / Suggested bases / Bases recommandées



Fijar 20
Fix 20
Fixar 20



Base de baldosas
Tiles base
Base delles



Base jardinera
Planter base
Base jardinière



Bases para empotrar
Built in bases
Bases à encastrer

TODAS LAS BASES /

ALL BASES /

TOUTES BASES

— p.64

Tabla de medidas / Available sizes / Tableau de mesures

SERIE
PALMA

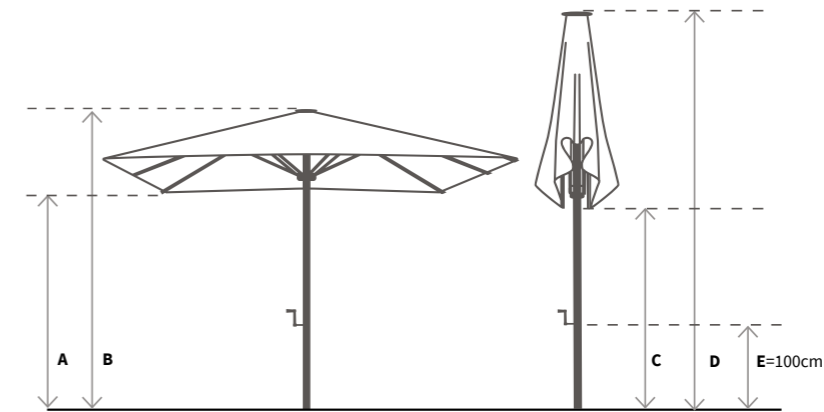

A- Altura varilla abierto
Rib height open
Hauteur baleine ouvert

B- Altura parasol abierto
Open parasol height
Hauteur parasol ouvert

C- Altura varilla cerrado
Rib height closed
Hauteur baleine fermé

D- Altura parasol cerrado
Closed parasol height
Hauteur parasol fermé

E- Altura manivela
Crank height
Hauteur manivelle

forma shape forme	medida measurement dimension	varillas ribs baleines	mástil pole mât	altura A height A hauteur A	altura B height B hauteur B	altura C height C hauteur C	altura D height D hauteur D	embalaje packaging emballage
	4m	8	ø90mm	225cm	282cm	162cm	364cm	40x40x367cm
	5m	8	ø90mm	225cm	314cm	160cm	421cm	40x40x424cm
	2'5x2'5m	8	ø90mm	225cm	276cm	169cm	349cm	40x40x352cm
	3x3m	8	ø90mm	225cm	293cm	138cm	356cm	40x40x359cm
	3'5x3'5m	8	ø90mm	225cm	291cm	137cm	387cm	40x40x390cm
	4x4m	8	ø90mm	225cm	296cm	99cm	386cm	40x40x389cm
	4'5x4'5m	8	ø90mm	225cm	309cm	76cm	400cm	40x40x403cm
	5x5m	8	ø90mm	225cm	319cm	56cm	417cm	40x40x420cm
	5'5x5'5m	8	ø90mm	225cm	329cm	36cm	433cm	40x40x436cm
	2x2'5m	8	ø90mm	225cm	265cm	169cm	329cm	40x40x332cm
	2x3m	8	ø90mm	225cm	273cm	154cm	334cm	40x40x337cm
	2x3'5m	8	ø90mm	225cm	284cm	153cm	357cm	40x40x360cm
	2x4m	8	ø90mm	225cm	279cm	135cm	359cm	40x40x362cm
	2'5x3m	8	ø90mm	225cm	263cm	146cm	338cm	40x40x341cm
	2'5x3'5m	8	ø90mm	225cm	278cm	140cm	354cm	40x40x357cm
	2'5x4m	8	ø90mm	225cm	282cm	132cm	368cm	40x40x371cm
	2'5x4'5m	8	ø90mm	225cm	287cm	109cm	367cm	40x40x370cm
	2'5x5m	8	ø90mm	225cm	293cm	105cm	386cm	40x40x389cm
	2'5x5'5m	8	ø90mm	225cm	314cm	88cm	396cm	40x40x399cm
	3x3'5m	8	ø90mm	225cm	291cm	165cm	398cm	40x40x401cm
	3x4m	8	ø90mm	225cm	265cm	133cm	378cm	40x40x381cm
	3x4'5m	8	ø90mm	225cm	291cm	98cm	370cm	40x40x373cm
	3x5m	8	ø90mm	225cm	309cm	95cm	391cm	40x40x394cm
	3x5'5m	8	ø90mm	225cm	312cm	72cm	390cm	40x40x393cm
	3'5x4m	8	ø90mm	225cm	315cm	159cm	433cm	40x40x436cm
	3'5x4'5m	8	ø90mm	225cm	300cm	90cm	379cm	40x40x382cm
	3'5x5m	8	ø90mm	225cm	316cm	82cm	394cm	40x40x397cm
	3'5x5'5m	8	ø90mm	225cm	317cm	83cm	415cm	40x40x418cm
	4x4'5m	8	ø90mm	225cm	308cm	96cm	403cm	40x40x406cm
4x5m	8	ø90mm	225cm	341cm	103cm	435cm	40x40x438cm	
4x5'5m	8	ø90mm	225cm	327cm	53cm	401cm	40x40x404cm	
4'5x5m	8	ø90mm	225cm	319cm	81cm	424cm	40x40x427cm	
4'5x5'5m	8	ø90mm	225cm	328cm	65cm	428cm	40x40x431cm	
5x5'5m	8	ø90mm	225cm	335cm	66cm	447cm	40x40x450cm	



SERIE PALMA DESPLAZADO

Parasol de aluminio
Aluminium parasol
Parasol en aluminium

ES

Parasol con las mismas características del Palma, con la diferencia que el mástil está situado a 50cm del lateral. Al ser un parasol con un mástil de 90mm, nos permite fabricar mayores dimensiones que el Elite de mástil desplazado. Permite crear grandes espacios cubiertos, sin la molestia de un mástil central. Ideal para aprovechar al máximo el espacio de tu terraza.

EN





Everything in this parasol is the same as the Palma model but its pole is located 50cm from the side. As it is a parasol with a 90mm pole, it allows larger dimensions than the shifted Elite. This model enables us to create large covered spaces without the inconvenience of a central pole. It is ideal for making the most of your terrace space.

FR

Parasol avec les mêmes caractéristiques que le Palma, avec la différence de son mât situé à 50cm du côté. Puisque c'est un parasol avec un mât de 90mm, il nous permet de fabriquer des dimensions plus grandes que l'Elite déplacé. Il facilite la création de grands espaces couverts, sans les inconvénients d'un mât central. Ce parasol est idéal pour profiter au maximum de votre espace terrasse.

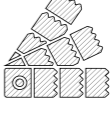
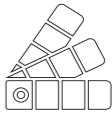
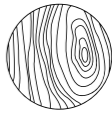
Mástil **TELESCÓPICO** Apertura **MANIVELA con usillo**
Pole **TELESCOPIC** Opening **CRANK with endless screw**
Mât **TÉLESCOPIQUE** Ouverture **MANIVELLE avec vis sans fin**

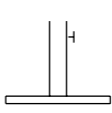
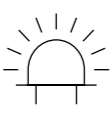
Opciones / Options / Options

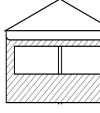
Acabados Finishes Finitions		 ref. TAS/TPS p. 84-87	 p.80	 p.81	 p.82
Accesorios Accessories Accessoires	 p.64-69	 p.70-73	 p.72	 p.74	 p.76

Características / Features / Caractéristiques

SERIE
PALMA DESPLAZADO

Colante y corona de aluminio y/o polietileno con soporte inox para las varillas.

Aluminium and/or polyethylene runner and notch with inox brackets for ribs.

Coulant et noix en aluminium et/ou polyéthylène avec support de baleine en inox.



Mástil de ø90cm. Estructura de aluminio lacado blanco. Sistema telescópico con manivela.

90cm pole. White coated aluminium frame. Telescopic opening system with crank.

Mât de ø90mm. Monture en aluminium laqué blanc. Système télescopique avec manivelle.



Perfil 20x40mm. Sujeción individual mediante tornillos.

Section 20x40mm ribs. Attached individually by screws.

Profile 20x40mm. Fixation individuelle par vis.



Bases recomendadas / Suggested bases / Bases recommandées



Fijar 20
Fix 20
Fixar 20



Base de baldosas
Tiles base
Base delles



Base jardinera
Planter base
Base jardinière



Bases para empotrar
Built in bases
Bases à encaster

TODAS LAS BASES /

ALL BASES /

TOUTES BASES

— p.64

Tabla de medidas / Available sizes / Tableau de mesures

SERIE
PALMA DESPLAZADO

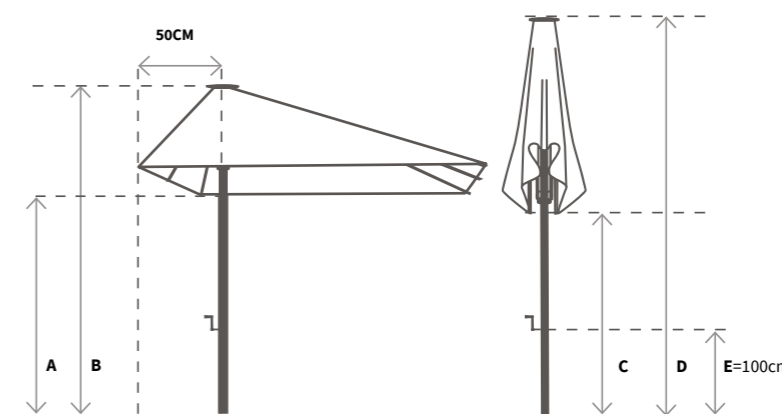

A - Altura varilla abierto
Rib height open
Hauteur baleine ouvert

B - Altura parasol abierto
Open parasol height
Hauteur parasol ouvert

C - Altura varilla cerrado
Rib height closed
Hauteur baleine fermé

D - Altura parasol cerrado
Closed parasol height
Hauteur parasol fermé

E - Altura manivela
Crank height
Hauteur manivelle

forma shape forme	medida measurement dimension	varillas ribs baleines	mástil pole mât	altura A height A hauteur A	altura B height B hauteur B	altura C height C hauteur C	altura D height D hauteur D	embalaje packaging emballage
	2,5x2,5m	6	ø90mm	225cm	285cm	185cm	367cm	40x40x368cm
	3x3m	6	ø90mm	225cm	306cm	106cm	402cm	40x40x406cm
	2x2'5m	6	ø90mm	225cm	271cm	171cm	365cm	40x40x368cm
	2x3m	6	ø90mm	225cm	271cm	129cm	381cm	40x40x384cm
	2x3'5m	6	ø90mm	225cm	282cm	146cm	377cm	40x40x380cm
	2x4m	6	ø90mm	225cm	277cm	132cm	380cm	40x40x383cm
	2x4'5m	6	ø90mm	225cm	283cm	123cm	393cm	40x40x396cm
	2'5x3m	6	ø90mm	225cm	279cm	152cm	400cm	40x40x403cm
	2'5x3'5m	6	ø90mm	225cm	287cm	144cm	410cm	40x40x413cm
	2'5x4m	6	ø90mm	225cm	294cm	134cm	419cm	40x40x421cm
	2'5x4'5m	6	ø90mm	225cm	302cm	106cm	410cm	40x40x413cm
	2,5x5m	6	ø90mm	225cm	313cm	92cm	417cm	40x40x420cm
	3x3,5m	6	ø90mm	225cm	310cm	104cm	413cm	40x40x416cm
	3x4m	6	ø90mm	225cm	314cm	93,2cm	417cm	40x40x420cm
	3x4,5m	6	ø90mm	225cm	318cm	95,6cm	437cm	40x40x440cm



SERIE BERLIN

Parasol de aluminio
Aluminium parasol
Parasol en aluminium

ES

Parasol de distinguido diseño; el único de nuestra colección con mástil cuadrado. Es un parasol firme y sólido idóneo para grandes terrazas. Al ser tan resistente permite la fabricación de grandes medidas. El uso de una manivela facilita su apertura.

EN

Parasol with a fine design; the only one in our collection with a square pole. It is a strong parasol suitable for large terraces. Its resistance allows to manufacture it in large sizes. The use of a crank makes it easy to open.

FR

Parasol avec design distingué; le seul dans notre collection avec un mât carré. C'est un parasol ferme et solide idéal pour des grandes terrasses. Sa résistance permet la fabrication de grandes dimensions. L'utilisation d'une manivelle permet de l'ouvrir facilement.

Mástil **TELESCÓPICO** Apertura **MANIVELA con usillo**
Pole **TELESCOPIC** Opening **CRANK with endless screw**
Mât **TÉLESCOPIQUE** Ouverture **MANIVELLE avec vis sans fin**

Opciones / Options / Options

Acabados
Finishes
Finitions

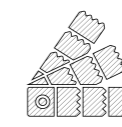

ref. **TAS/TPS**
p. 84-87



p.80



p.82

Accesorios
Accessories
Accessoires

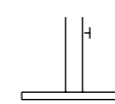

p.64-69

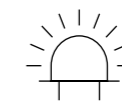

p.70-73



p.72



p.74

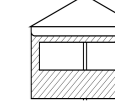

p.76

Características / Features / Caractéristiques

SERIE
BERLIN

Corona de aluminio y colante de polietileno con soporte inox para las varillas.

Aluminium notch and polyethylene runner with inox brackets for ribs.

Noix en aluminium et coulant en polyéthylène avec support de baleine en inox.

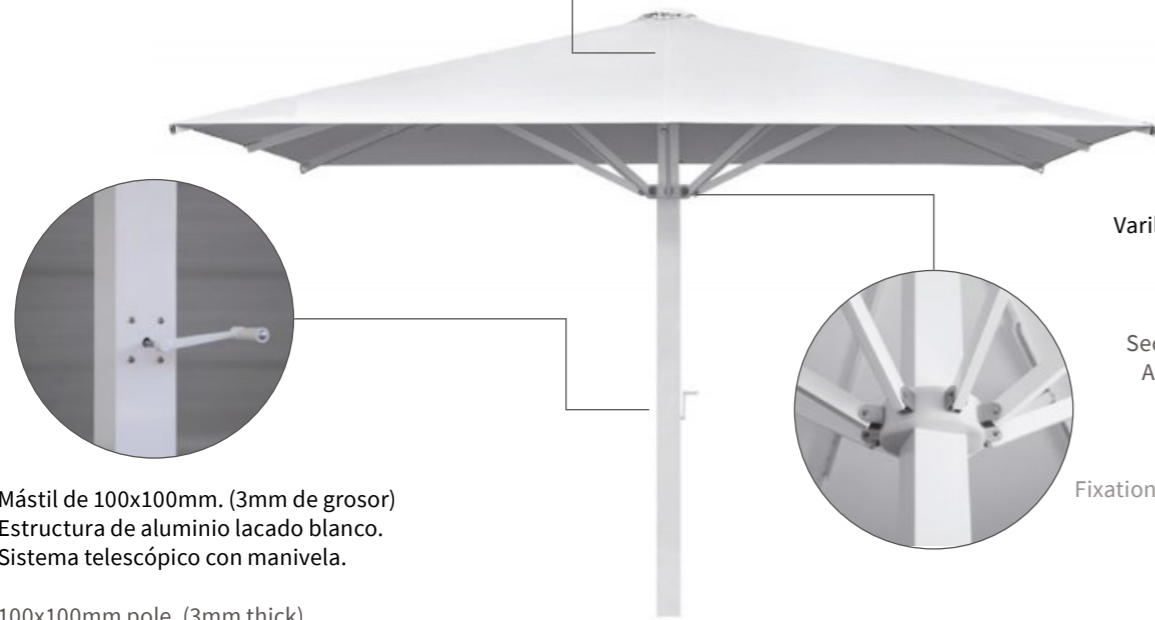

Varillas perfil 20x40mm.
Sujeción individual mediante tornillos.

Section 20x40mm ribs.
Attached individually by screws.

Profile 20x40mm.
Fixation individuelle par vis.

Mástil de 100x100mm. (3mm de grosor)
Estructura de aluminio lacado blanco.
Sistema telescópico con manivela.

100x100mm pole. (3mm thick).
White coated aluminium frame
Telescopic opening system with crank.

Mât de 100x100mm. (3mm d'épaisseur)
Monture en aluminium laqué blanc.
Système télescopique avec manivelle.



Bases recomendadas / Suggested bases / Bases recommandées



Fijar 20
Fix 20
Fixar 20



Base de baldosas
Tiles base
Base delles



Base jardinera
Planter base
Base jardinière



Bases para empotrar
Built in bases
Bases à encaster

TODAS LAS BASES /

ALL BASES /

TOUTES BASES

— p.64

Tabla de medidas / Available sizes / Tableau de mesures

SERIE
BERLIN

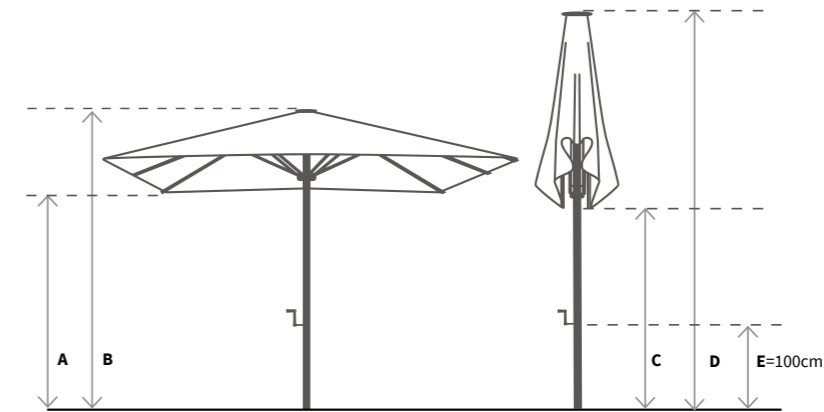

A - Altura varilla abierto
Rib height open
Hauteur baleine ouvert

B - Altura parasol abierto
Open parasol height
Hauteur parasol ouvert

C - Altura varilla cerrado
Rib height closed
Hauteur baleine fermé

D - Altura parasol cerrado
Closed parasol height
Hauteur parasol fermé

E - Altura manivela
Crank height
Hauteur manivelle

forma shape forme	medida measurement dimension	varillas ribs baleines	mástil pole mât	altura A height A hauteur A	altura B height B hauteur B	altura C height C hauteur C	altura D height D hauteur D	embalaje packaging emballage
	4m	8	100x100mm	225cm	282cm	162cm	364cm	40x40x367cm
	5m	8	100x100mm	225cm	314cm	160cm	421cm	40x40x424cm
	3x3m	8	100x100mm	225cm	293cm	138cm	356cm	40x40x359cm
	3'5x3'5m	8	100x100mm	225cm	291cm	137cm	387cm	40x40x390cm
	4x4m	8	100x100mm	225cm	296cm	99cm	386cm	40x40x389cm
	4'5x4'5m	8	100x100mm	225cm	309cm	76cm	400cm	40x40x403cm
	5x5m	8	100x100mm	225cm	319cm	56cm	417cm	40x40x420cm
	5'5x5'5m	8	100x100mm	225cm	329cm	36cm	433cm	40x40x436cm
	2x3m	8	100x100mm	225cm	273cm	154cm	334cm	40x40x337cm
	2x3'5m	8	100x100mm	225cm	284cm	153cm	357cm	40x40x360cm
	2x4m	8	100x100mm	225cm	279cm	135cm	359cm	40x40x362cm
	2'5x3m	8	100x100mm	225cm	263cm	146cm	338cm	40x40x341cm
	2'5x3'5m	8	100x100mm	225cm	278cm	140cm	354cm	40x40x357cm
	2'5x4m	8	100x100mm	225cm	282cm	132cm	368cm	40x40x371cm
	2'5x4'5m	8	100x100mm	225cm	287cm	109cm	367cm	40x40x370cm
	2'5x5m	8	100x100mm	225cm	293cm	105cm	386cm	40x40x389cm
	3x3'5m	8	100x100mm	225cm	291cm	165cm	398cm	40x40x401cm
	3x4m	8	100x100mm	225cm	265cm	133cm	378cm	40x40x381cm
	3x4'5m	8	100x100mm	225cm	291cm	98cm	370cm	40x40x373cm
	3x5m	8	100x100mm	225cm	309cm	95cm	391cm	40x40x394cm
	3x6m	8	100x100mm	225cm	324cm	100cm	443cm	40x40x446cm
	3'5x4m	8	100x100mm	225cm	315cm	159cm	433cm	40x40x436cm
	3'5x4'5m	8	100x100mm	225cm	300cm	90cm	379cm	40x40x382cm
	3'5x5m	8	100x100mm	225cm	316cm	82cm	394cm	40x40x397cm
	3'5x6m	8	100x100mm	225cm	327cm	91,4cm	446cm	40x40x449cm
	4x4'5m	8	100x100mm	225cm	308cm	96cm	403cm	40x40x406cm
	4x5m	8	100x100mm	225cm	341cm	103cm	435cm	40x40x438cm
	4x5'5m	8	100x100mm	225cm	327cm	53cm	401cm	40x40x404cm
4'5x5m	8	100x100mm	225cm	319cm	81cm	424cm	40x40x427cm	
4'5x5'5m	8	100x100mm	225cm	328cm	65cm	428cm	40x40x431cm	
5x5'5m	8	100x100mm	225cm	335cm	66cm	447cm	40x40x450cm	



SERIE BERLIN DESPLAZADO

Parasol de aluminio
Aluminium parasol
Parasol en aluminium

ES

Parasol con las mismas características del Berlin, con la diferencia de su mástil situado a 50cm del lateral. Al ser un parasol con un mástil de 100x100mm, nos permite fabricar mayores dimensiones. Permite crear grandes espacios cubiertos, sin la molestia de un mástil central. Ideal para aprovechar al máximo el espacio de tu terraza.

EN

Everything in this parasol is the same as the Berlin model but its pole is located 50cm from the side. Being a parasol with a 100x100mm pole, it allows for larger dimensions. This model enables us to create large covered spaces without the inconvenience of a central pole. It is ideal for making the most of your terrace space.

FR

Parasol avec les mêmes caractéristiques que le Berlin, avec la différence de son mât situé à 50cm du côté. Puisque c'est un parasol avec un mât de 100x100mm, il nous permet de fabriquer des dimensions plus grandes. Il facilite la création de grands espaces couverts, sans les inconvénients d'un mât central. Ce parasol est idéal pour profiter au maximum de votre espace terrasse.

Mástil **TELESCÓPICO** Apertura **MANIVELA con usillo**
Pole **TELESCOPIC** Opening **CRANK with endless screw**
Mât **TÉLESCOPIQUE** Ouverture **MANIVELLE avec vis sans fin**

Opciones / Options / Options

Acabados
Finishes
Finitions

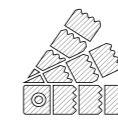

ref. **TAS/TPS**
p. 84-87

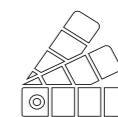

p.80



p.82

Accesorios
Accessories
Accessoires

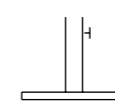

p.64-69

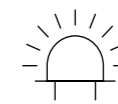

p.70-73



p.72



p.74

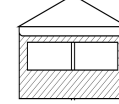

p.76

Características / Features / Caractéristiques

SERIE
BERLIN DESPLAZADO

Corona de aluminio y colante de polietileno con soporte inox para las varillas.

Aluminium notch and polyethylene runner with inox brackets for ribs.

Noix en aluminium et coulant en polyéthylène avec support de baleine en inox.



Mástil de 100x100mm. (3mm de grosor)
Estructura de aluminio lacado blanco.
Sistema telescópico con manivela.

100x100mm pole. (3mm thick).
White coated aluminium frame
Telescopic opening system with crank.

Mât de 100x100mm. (3mm d'épaisseur)
Monture en aluminium laqué blanc.
Système télescopique avec manivelle.



Varillas perfil 20x40mm.
Sujeción individual mediante tornillos.

Section 20x40mm ribs.
Attached individually by screws.

Profile 20x40mm.
Fixation individuelle par vis.



Bases recomendadas / Suggested bases / Bases recommandées



Fijar 20
Fix 20
Fixar 20



Base de baldosas
Tiles base
Base delles



Base jardinera
Planter base
Base jardinière



Bases para empotrar
Built in bases
Bases à encaster

TODAS LAS BASES /

ALL BASES /

TOUTES BASES

— p.64

Tabla de medidas / Available sizes / Tableau de mesures

SERIE
BERLIN DESPLAZADO

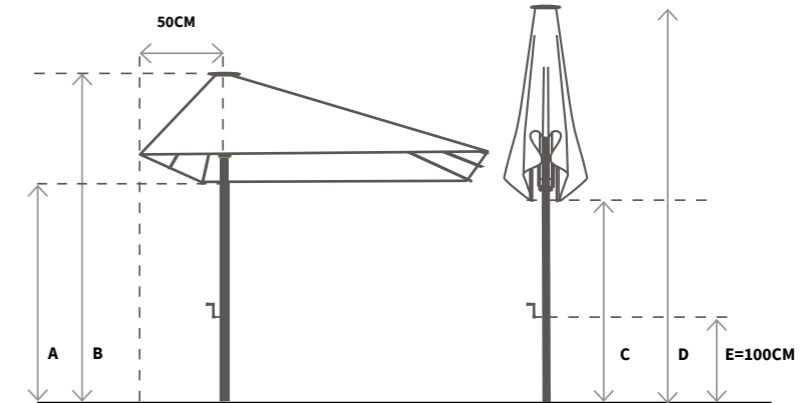

A - Altura varilla abierto
Rib height open
Hauteur baleine ouvert

B - Altura parasol abierto
Open parasol height
Hauteur parasol ouvert

C - Altura varilla cerrado
Rib height closed
Hauteur baleine fermé

D - Altura parasol cerrado
Closed parasol height
Hauteur parasol fermé

E - Altura manivela
Crank height
Hauteur manivelle

forma shape forme	medida measurement dimension	varillas ribs baleines	mástil pole mât	altura A height A hauteur A	altura B height B hauteur B	altura C height C hauteur C	altura D height D hauteur D	embalaje packaging emballage
-------------------------	------------------------------------	------------------------------	-----------------------	-----------------------------------	-----------------------------------	-----------------------------------	-----------------------------------	------------------------------------

	2,5x2,5m	6	100x100mm	225cm	285cm	185cm	367cm	40x40x368cm
	3x3m	6	100x100mm	225cm	306cm	106cm	402cm	40x40x406cm

	2x2'5m	6	100x100mm	225cm	271cm	171cm	365cm	40x40x368cm
	2x3m	6	100x100mm	225cm	271cm	129cm	381cm	40x40x384cm
	2x3'5m	6	100x100mm	225cm	282cm	146cm	377cm	40x40x380cm
	2x4m	6	100x100mm	225cm	277cm	132cm	380cm	40x40x383cm
	2x4'5m	6	100x100mm	225cm	283cm	123cm	393cm	40x40x396cm
	2'5x3m	6	100x100mm	225cm	279cm	152cm	400cm	40x40x403cm
	2'5x3'5m	6	100x100mm	225cm	287cm	144cm	410cm	40x40x413cm
	2'5x4m	6	100x100mm	225cm	294cm	134cm	419cm	40x40x421cm
	2'5x4'5m	6	100x100mm	225cm	302cm	106cm	410cm	40x40x413cm
	2,5x5m	6	100x100mm	225cm	313cm	92cm	417cm	40x40x420cm
	3x3,5m	6	100x100mm	225cm	310cm	104cm	413cm	40x40x416cm
	3x4m	6	100x100mm	225cm	314cm	93,2cm	417cm	40x40x420cm
	3x4,5m	6	100x100mm	225cm	318cm	95,6cm	437cm	40x40x440cm



SERIE GOLD EXTRA

Parasol de madera
Wood parasol
Parasol en bois

ES

Parasol resistente y de mayores dimensiones gracias a sus sólidas varillas de aluminio imitación madera. Junto con el mástil, el colante y la corona de madera, proyectan una imagen totalmente rústica. Es ideal para crear un entorno rural.

EN

Strong and larger parasol thanks to its solid aluminium ribs in wood imitation. Along with the pole, the runner and the notch all made of wood, this model displays an absolutely rustic style. It is ideal for creating a rural environment.

FR

Parasol robuste et plus grand grâce à ses baleines résistantes en aluminium imitation bois. Avec le mât, le coulant et la noix en bois, ce modèle projette une image totalement rustique. Il est idéal pour créer un environnement rural.

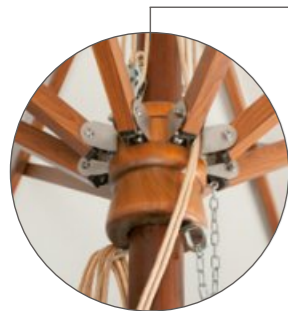

Sistema de apertura con 2 poleas dobles.
Colante y corona de madera.

Opening system by 2 double pulley.
Wood runner and notch.

Système d'ouverture par 2 poulies doubles.
Coulant et noix en bois.



Mástil de $\varnothing 60$ mm.
Montura de madera tropical tratada para exterior.
Color nogal medio.

$\varnothing 60$ mm pole.
Tropical hard wood for outside spaces frame.
Walnut color.

Mât en $\varnothing 60$ mm.
Monture en bois de îles pour extérieur.
Couleur noyer.

Opciones / Options / Options

Acabados
Finishes
Finitions

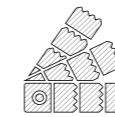

ref. TOP / TAS
p. 84-87

p.82

Accesorios
Accessories
Accessoires

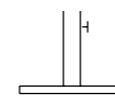

p.64-69

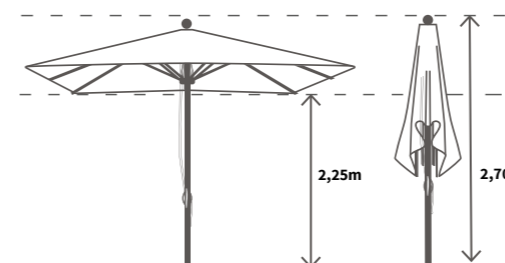

Medidas / Measures / Mesures

Forma
Shape
Forme

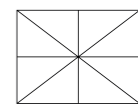
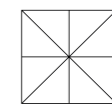
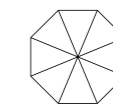

$\varnothing 3$ m	2x2m	2x3m
$\varnothing 3.5$ m	2.5x2.5m	3x4m
$\varnothing 4$ m	3x3m	
$\varnothing 5$ m	3.5x3.5m	
	4x4m	





SERIE LUXE

Parasol de madera
Wood parasol
Parasol en bois

ES

Parasol fuerte y robusto caracterizado por su mástil cuadrado de madera y su elegante colante de madera. Es un parasol idóneo para darle un ambiente rústico y cálido a su lujosa terraza.

EN

Strong and robust parasol featuring a square wooden pole and elegant wooden runner. It is an ideal parasol to provide your luxurious terrace with a rustic and warm atmosphere.

FR

Parasol robuste et solide caractérisé par son mât carré en bois et son élégant coulant en bois. C'est un parasol idéal pour donner une ambiance rustique et chaleureuse à votre terrasse luxueuse.

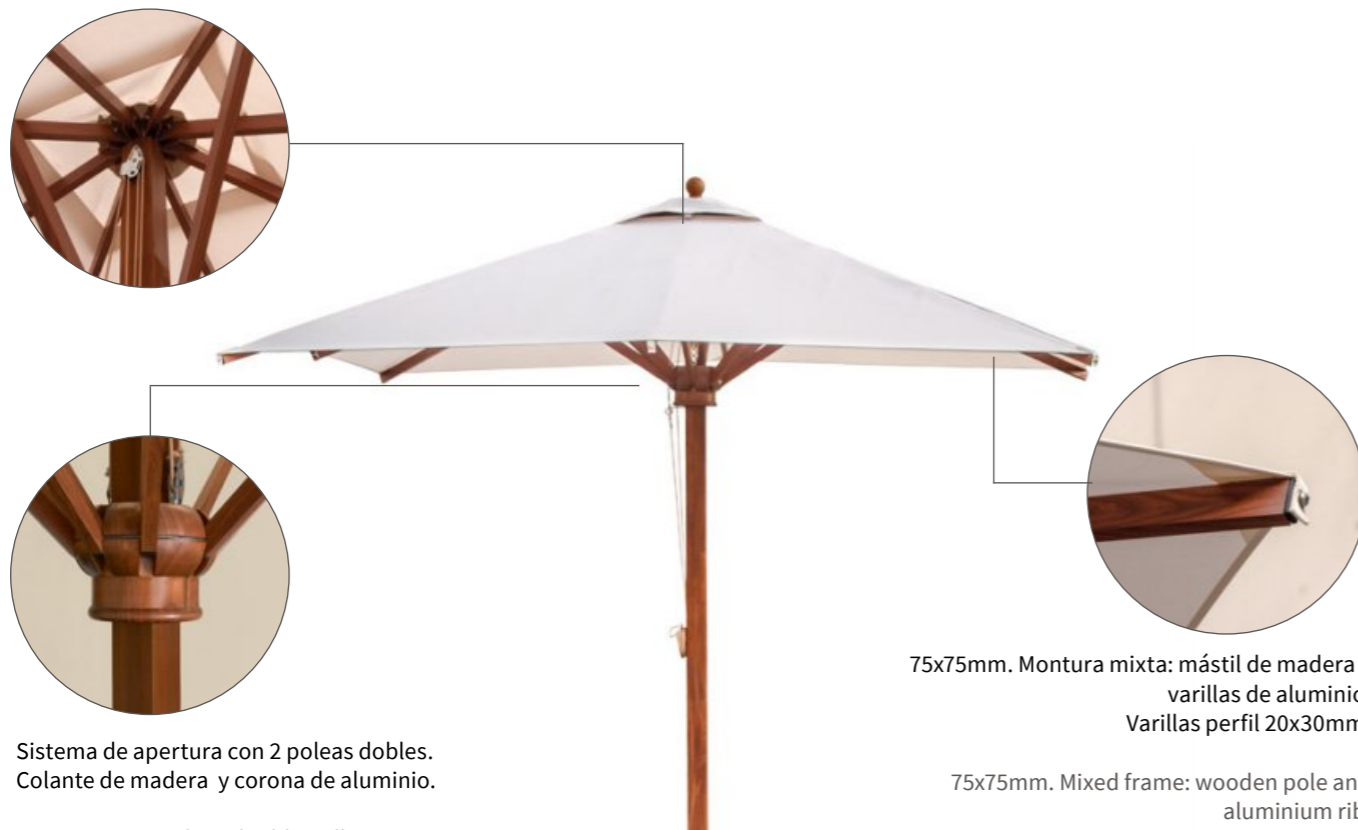

75x75mm. Montura mixta: mástil de madera y varillas de aluminio.
Varillas perfil 20x30mm.

75x75mm. Mixed frame: wooden pole and aluminium rib.
Ribs section 20x30mm.

75x75mm. Structure mixte: mât en bois et baleines en aluminium.
Balaines profil 20x30mm.

Sistema de apertura con 2 poleas dobles.
Colante de madera y corona de aluminio.

Opening system by 2 double pulleys.
Wood runner and aluminium notch.

Système d'ouverture par 2 poulies doubles.
Coulant en bois et noix en aluminium.

Opciones / Options / Options

Acabados
Finishes
Finitions

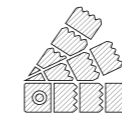

ref. TOP / TAS
p. 84-87

p.82

Accesorios
Accessories
Accessoires

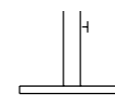

p.64-69

Medidas / Measures / Mesures

Forma
Shape
Forme

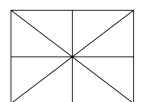
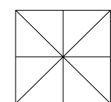
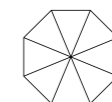

ø3.5m

3x3m

2x3m

ø4m

3.5x3.5m

3x4m

ø5m

4x4m

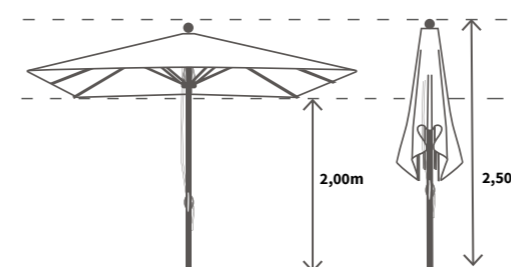



Sistema de apertura mediante 2 poleas.
Colante y corona de plástico.

Opening system by 2 pulley.
Plastic runner and notch.

Système d'ouverture par 2 poulies.
Coulant et noix en plastique.



Mástil de $\varnothing 38/48\text{mm}$.
Montura de madera tropical tratada para exterior. Color nogal medio.

$\varnothing 38/48\text{mm}$ pole.
Tropical hard wood for outside spaces frame.
Walnut color.

Mât en $\varnothing 38/48\text{mm}$.
Monture en bois de îles pour extérieur.
Couleur noyer.

SERIE CLASSIC

Parasol de madera
Wood parasol
Parasol en bois

ES

Parasol ligero y de dimensiones reducidas, ideal para recoger a diario. Tiene un diseño cálido y coqueto, perfecto para adaptarse en los entornos naturales más bonitos.

EN

Lightweight, small-sized parasol, ideal for picking up every day. It has a warm and charming design that fits perfectly in the most beautiful natural environments.

FR

Parasol léger de petite taille, idéal pour ranger chaque jour. Il a un design chaleureux et flirtant, parfait pour s'intégrer dans les plus beaux environnements naturels.

Opciones / Options / Options

Acabados
Finishes
Finitions

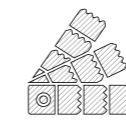

ref. TPA / TOP
p. 84-87

p.82

Accesorios
Accessories
Accessoires



p.64-69

Medidas / Measures / Mesures

Forma
Shape
Forme

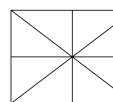
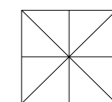
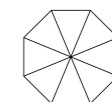

$\varnothing 2\text{m}$

2x2m

2x3m

$\varnothing 2.4\text{m}$

2.5x2.5m

$\varnothing 3\text{m}$

3x3m

$\varnothing 3.5\text{m}$

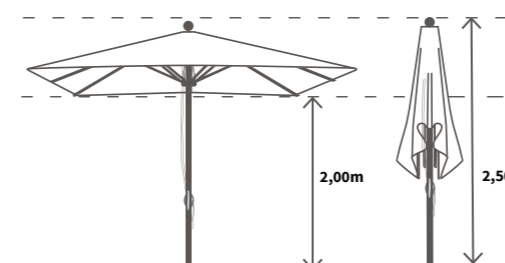

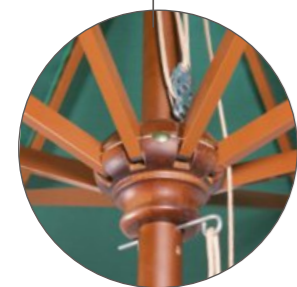

Sistema de apertura con 2 poleas.
Colante y corona de madera.

Opening system by 2 pulley.
Wood runner and notch.

Système d'ouverture par 2 poulies.
Coulant et noix en bois.



Mástil de madera tropical tratada para exterior color nogal medio ø50mm.
Perfil de aluminio RAL marrón 15x25mm.

Tropical hard wood for outside spaces Walnut color pole. ø50mm.
Aluminium RAL brown section 15x25mm.

Mât en bois de îles pour extérieur couleur noyer. ø50mm.
Profil en aluminium RAL marron 15x25mm.

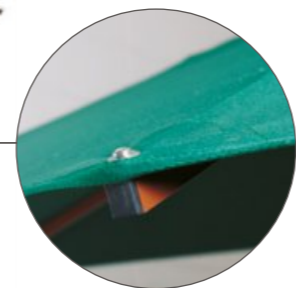

SERIE NIZA

Parasol de madera
Wood parasol
Parasol en bois

ES

Parasol ligero ideal para los amantes de la madera que buscan solidez en sus parasoles. Las varillas de aluminio marrón se mimetizan con la naturaleza obteniendo así la calidez de la madera con la resistencia del aluminio.

EN

Lightweight parasol that is ideal for wood lovers looking for solidity in their parasols. The brown aluminium ribs blend in with nature, thus obtaining the warmth of wood combined with the strength of aluminium.

FR

Parasol léger idéal pour les amoureux du bois qui recherchent la solidité dans leurs parasols. Les baleines d'aluminium marron se mélangent avec la nature pour offrir la chaleur du bois avec la force de l'aluminium.

Opciones / Options / Options

Acabados
Finishes
Finitions

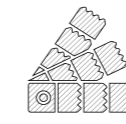

ref. TPA/TOP/TAS
p. 84-87

p.82

Accesorios
Accessories
Accessoires

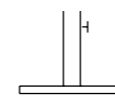

p.64-69

Medidas / Measures / Mesures

Forma
Shape
Forme

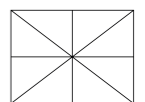
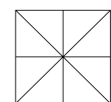
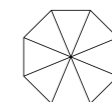

ø2m	2x2m	2x2.5m
ø2.4m	2.5x2.5m	2x3m
ø3m	3x3m	2.5x3m
ø3.5m		
ø4m		

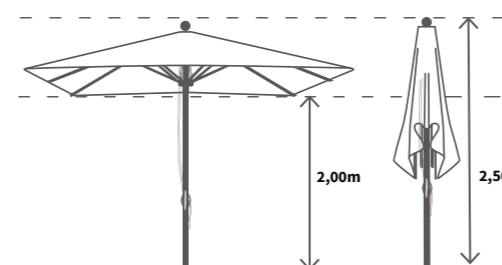

12-25Kg



SERIE BASIC

Parasol de madera
Wood parasol
Parasol en bois

ES

Parasol de madera ligero. La estructura es desmontable en dos piezas, ideal para poder guardar en espacios muy reducidos. Este parasol se puede utilizar tanto en pequeñas terrazas, como para uso particular. Disponible en tejido spunpoly crudo (servicio inmediato) y en tejido polisilk con nuestros colores de stock.

EN

Lightweight wooden parasol whose frame is detachable in two parts, ideal for storage in very small spaces. This parasol can be used both in small terraces and for private use. It is available in spunpoly fabric in ecru color (quick service) and in polisilk fabric with our stock colours.

FR

Parasol léger en bois. La monture est démontable en deux parties, idéale pour le stockage dans des espaces très réduits. Ce parasol peut être utilisé aussi bien sur de petites terrasses que pour l'usage privé. Disponible en tissu spunpoly couleur crème (service immédiat) et en tissu polisilk en nos couleurs de stock.



Colante y corona de plástico.
 Plastic runner and notch.
 Coulant et noix en plastique.

Varillas de perfil 17x22mm.
 Sujecion conjunta mediante alambre.

Section 17x22mm ribs.
 Attached together by wire.

Profil 17x22mm.
 Fixation conjointe par fil de fer.

Madera tropical de importación.
 Mástil de ø48mm.
 Sistema de apertura con 2 poleas.

Import tropical hard wood. ø48mm pole.
 Pulley opening system

Bois en tropical d'importation.
 Mât en ø48mm.
 Système d'ouverture par deux poulies.

Opciones / Options / Options

Acabados
 Finishes
 Finitions

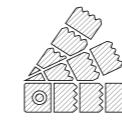

ref. TPA / TOP
 p. 84-87

p.82

Accesorios
 Accessories
 Accessoires

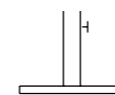

p.64-69

Medidas / Measures / Mesures

Forma
 Shape
 Forme

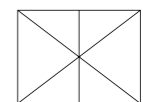
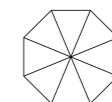

ø2m

2x3m



Color de stock
 Stock color
 Couleur de stock

CREMA
 Spunpoly

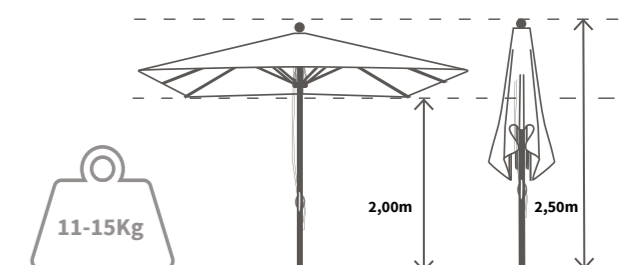



SERIE POOL MADERA

Parasol de madera
Wood parasol
Parasol en bois

ES

Parasol en forma decagonal y cuadrado ideal para tu piscina. Se fabrica en tejido polisilk con nuestros colores de stock y posibilidad de acabado con flecos.

EN

Decagonal and square parasol that is ideal for your pool. It is manufactured in polisilk fabric with our stock colors.

FR

Parasol décagonal et carré idéal pour votre piscine. Il est fabriqué en tissu polisilk en nos couleurs de stock.



Decagonal :10 varillas de fibra Ø8mm.
Cuadrado: 8 varillas de fibra Ø8mm.

Decagonal: 10 fiber ribs Ø8mm.
Square: 8 fiber ribs Ø8mm.

Décagonal: 10 baleines en fibre Ø8mm.
Carré: 8 baleines en fibre Ø8mm.

Mástil madera color nogal.
Wood pole walnut color.
Poteau en bois couleur noyer.

Opciones / Options / Options

Acabados
Finishes
Finitions



ref. TPA / TOP
p. 84-87

p.82

Accesorios
Accessories
Accessoires

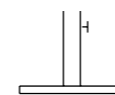

p.64-69

Medidas / Measures / Mesures

Forma
Shape
Forme

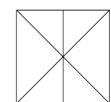
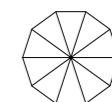

Ø2m

2x2m

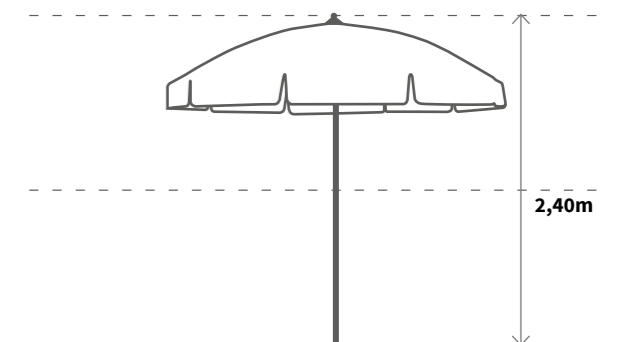

SERIE POOL

Aluminio estriado

ES
Parasol en forma decagonal y cuadrado ideal para tu piscina. Se fabrica en tejido polisilk con nuestros colores de stock.

EN
Decagonal and square parasol that is ideal for your pool. It is manufactured in polisilk fabric with our stock colors.

FR
Parasol décagonal et carré idéal pour votre piscine. Il est fabriqué en tissu polisilk en nos couleurs de stock.

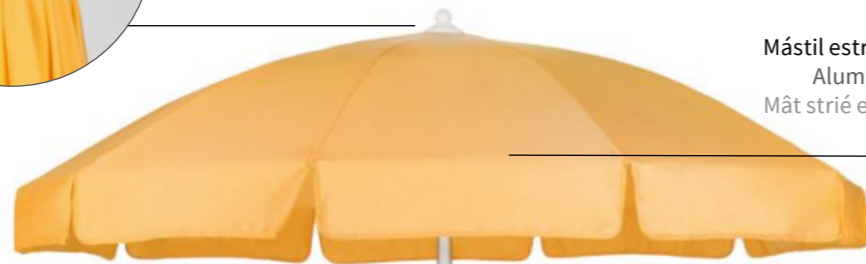

Mástil estriado de aluminio color plata.
Aluminium fluted pole silver color.
Mât strié en aluminium Couleur argent.

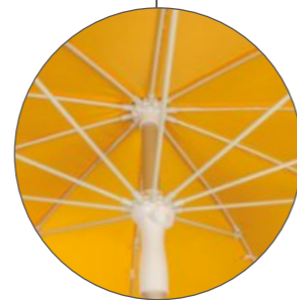

Decagonal :10 varillas de fibra Ø8mm.
Cuadrado: 8 varillas de fibra Ø8mm.

Decagonal: 10 fiber ribs Ø8mm.
Square: 8 fiber ribs Ø8mm.

Décagonal: 10 baleines en fibre Ø8mm.
Carré: 8 baleines en fibre Ø8mm.

Ø36-40mm.
De 2 piezas y altura regulable. No inclinable.

Ø36-40mm.
Height adjustable two piece pole. Non-tiltable.

Ø36-40mm.
Mât de 2 pièces et hauteur réglable. Non reclinable.

Opcional
Optional
Optionnel

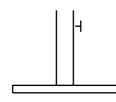

p.64-69

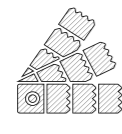

ref. TPA / TOP
p. 84-87



p.82

Medidas
Measures
Mesures

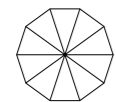

2m

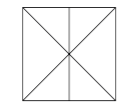

2x2m

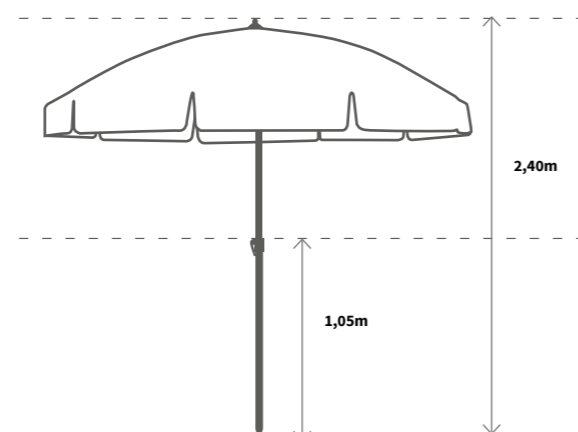

SERIE SINTRA



Funda de protección incluida.
Protection cover included.
Housse de protection incluse.

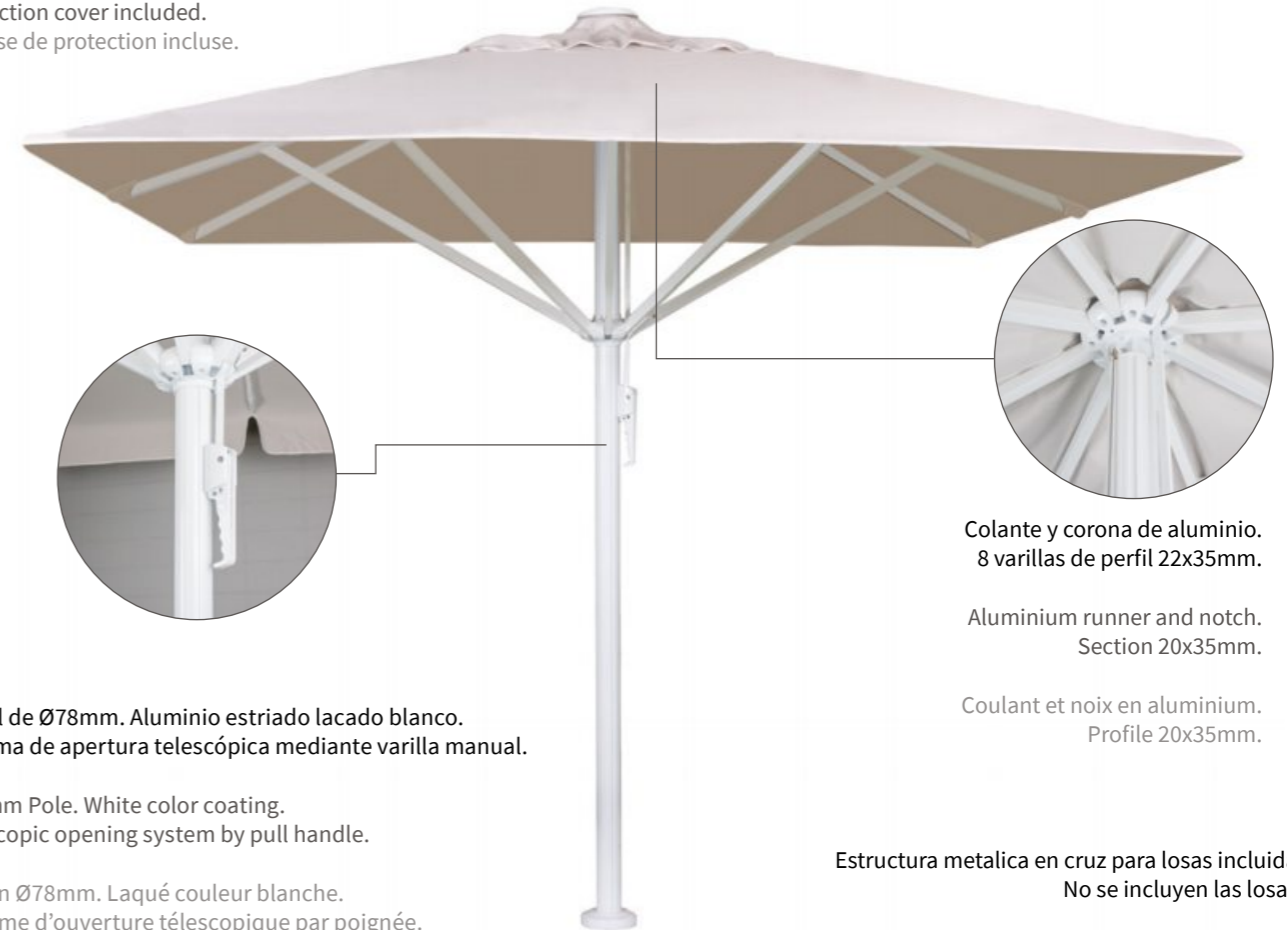

Mástil de Ø78mm. Aluminio estriado lacado blanco.
Sistema de apertura telescópica mediante varilla manual.

Ø78mm Pole. White color coating.
Telescopic opening system by pull handle.

Mât en Ø78mm. Laqué couleur blanche.
Système d'ouverture télescopique par poignée.

Colante y corona de aluminio.
8 varillas de perfil 22x35mm.

Aluminium runner and notch.
Section 20x35mm.

Coulant et noix en aluminium.
Profile 20x35mm.

Estructura metálica en cruz para losas incluida.
No se incluyen las losas.

Cross metal structure for slabs included.
Slabs are not included.

Structure métallique en croix pour dalles incluse.
Les dalles ne sont pas incluses.

Opcional
Optional
Optionnel

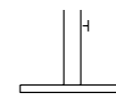

p.64-69



p.82

Tejido color
Fabric color
Tissu couleur



MARFIL
Poliéster
300g/m²
ref. Poliéster

SIN VOLANTE
WITHOUT VALANCE
SANS VOLANT

Medidas
Measures
Mesures

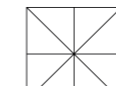

4x4m
5x5m

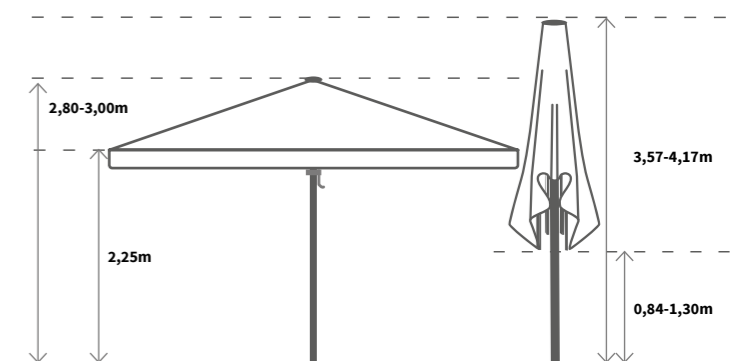

SERIE STREET



Mástil de Ø48/50mm.
Sistema de apertura de poleas.

Ø48/50mm Pole.
Opening system by pulleys.

Mât en ø48/50mm.
Système d'ouverture par poulie.

Colante y corona de plástico.
8 varillas de 15x25mm.

Plastic runner and notch.
8 ribs 15x25mm.

Coulant et noix en plastique.
8 baleines 15x25mm.

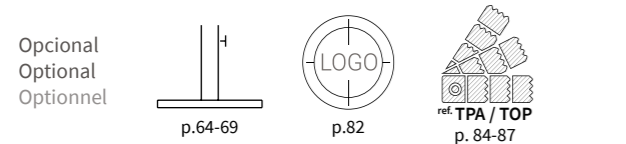

Tejido color
Fabric color
Tissu couleur

MARFIL
Poliester
235g/m²
ref. Poliester



Medidas
Measures
Mesures

2x2m 2x3m

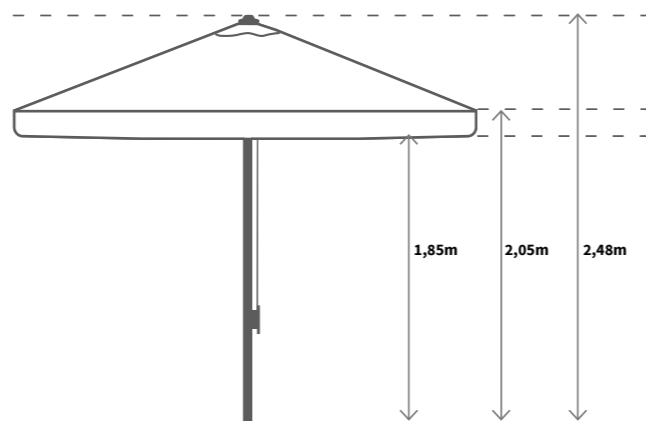

ES

Parasol disponible en tejido poliéster color natural (servicio inmediato) y en tejido polisilk con nuestros colores de stock. Se trata de un parasol ligero y fácil de manejar. Es ideal para eventos, ceremonias al aire libre y para el uso particular.

EN

Parasol available in natural colored polyester fabric (quick service) and in polisilk fabric with our stock colors. It is a lightweight and easy to handle model. This parasol is ideal for events, outdoor ceremonies and for private use.

FR

Parasol disponible en tissu polyester de couleur naturelle (service immédiat) et en tissu polisilk en nos couleurs de stock. C'est un parasol léger et facile à manipuler. Il est idéal pour des événements, des cérémonies en plein air et pour l'usage privé.

Montura acabado anodizado gris.
Anodisen gray aluminium frame.
Monture finition anodisée grise.



Mástil de Ø48mm.
Sistema de apertura de poleas.

Ø48mm Pole.
Opening system by pulleys.

Mât en ø48mm.
Système d'ouverture par poulie.

Colante y corona de plástico.
8 varillas de 17x22mm.

Plastic runner and notch.
8 ribs 17x22mm.

Coulant et noix en plastique.
8 baleines 17x22mm.

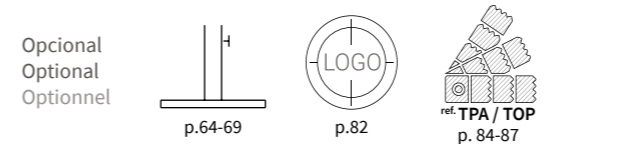

Tejido color
Fabric color
Tissu couleur

MARFIL
Poliester
235g/m²
ref. Poliester



Medidas
Measures
Mesures

3m

Bases

Bases / Bases

Base de polietileno rellenable / Refill polythene base / Polythene base rechargeable

	Base de superficie Surface base Base de surface		
	Con el tubo desmontable. Rellenable With removable tube. Refillable Avec tube démontable. Rechargeable		
	Color Colour Couleur		
	Peso Weight Lester	1,2kg – 15kg	

Para / For / Pour : SERIE POOL

Base hormigón / Concrete base / Base de béton

	Base de superficie Surface base Base de surface		
	Con el tubo fijo With fixed tube Avec tube fixe		
	Color Colour Couleur		
	Peso Weight Lester	15kg	

Para / For / Pour : SERIE POOL - CLASSIC (2M-6)

Hormigón recubierto / Coated concrete/ Béton enduit

	Base de superficie Surface base Base de surface		
	Con el tubo desmontable With removable tube Avec tube démontable		
	Color Colour Couleur		
	Peso Weight Lester	30kg	

Para / For / Pour : SERIE POOL - STREET - BASIC - CLASSIC - ESTANDAR - NIZA - NATURFUST

Hormigón recubierto y ruedas / Coated concrete and wheels/ Béton enduit et roues

	Base de superficie Surface base Base de surface		
	Con el tubo desmontable y ruedas With removable tube and wheels Avec tube démontable et roues		
	Color Colour Couleur		
	Peso Weight Lester	40kg	

Para / For / Pour : SERIE POOL - STREET - BASIC - CLASSIC - ESTANDAR - NIZA - NATURFUST

Base de granito / Granite base / Base de granit

	Base de superficie Surface base Base de surface		
	Con el tubo desmontable With removable tube Avec tube démontable		
	Color Colour Couleur		
	Peso Weight Lester	35kg / 50kg	



Para / For / Pour : SERIE CLASSIC - BASIC - ESTANDAR - NIZA - GOLD EXTRA

Resinada rellenable / Refill resined / Résine rechargeable

	Base de superficie Surface base Base de surface		
	Con el tubo desmontable. Rellenable With removable tube. Refillable Avec tube démontable. Rechargeable		
	Colores Colours Couleurs		
	Peso Weight Lester	5kg – 70kg	

Para / For / Pour : GOLD EXTRA - ESTANDAR - ESTANDAR EXTRA

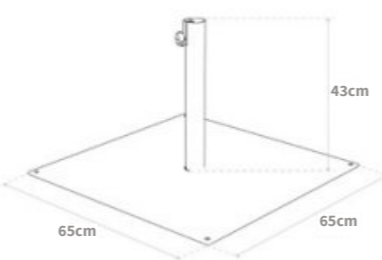
Metalica 65-6 / Metallic 65-6 / Metallique 65-6

	Base de superficie Surface base Base de surface		
	Con el tubo fijo With fixed tube Avec tube fixe		
	Colores Colours Couleurs		
	Peso Weight Lester	23kg	



Para / For / Pour : SERIE BASIC - CLASSIC - ESTANDAR - NIZA

Metalica 65 / Metallic 65 / Metallique 65

	Base de superficie Surface base Base de surface		
	Con el tubo desmontable With removable tube Avec tube démontable		
	Colores Colours Couleurs		
	Peso Weight Lester	35kg / 55kg / 75kg / 105kg	

Para / For / Pour : TODAS LAS SERIES - ALL SERIES - TOUTES LES SÉRIES

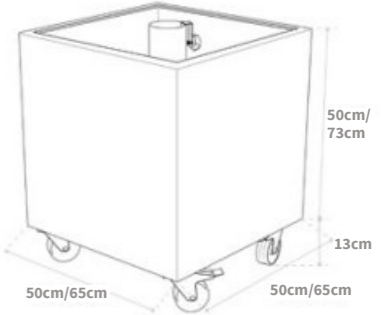
Base jardinera / Planter base / Base jardinière

	Base de superficie Surface base Base de surface		
	Con el tubo desmontable y ruedas With removable tube and wheels Avec tube démontable et roues		
	Colores Colours Couleurs		
	Peso Weight Lester	50x50x50cm = 50kg / 200kg (llena / full / pleine) 65x65x50cm = 65kg / 250kg (llena / full / pleine) 65x65x73cm = 80kg / 400kg (llena / full / pleine)	

Para / For / Pour : TODAS LAS SERIES - ALL SERIES - TOUTES LES SÉRIES

Fijar 10 / Fix 10 / Fixer 10

	Base para fijar al suelo Base to fix the ground Base à fixer au sol		
	Con el tubo fijo With fixed tube Avec tube fixe		
	Colores Colours Couleurs		
	Peso Weight Lester	10kg	

Para / For / Pour : SERIE STREET - CLASSIC - ESTANDAR - NIZA - NATURFUST

Fijar 20 / Fix 20 / Fixer 20

	Base para fijar al suelo Base to fix the ground Base à fixer au sol		
	Con el tubo fijo With fixed tube Avec tube fixe		
	Colores Colours Couleurs		
	Peso Weight Lester	20kg	

Para / For / Pour : TODAS LAS SERIES - ALL SERIES - TOUTES LES SÉRIES

Empotrar 3 piezas / Built-in base 3 pieces / Encastrar, 3 pièces

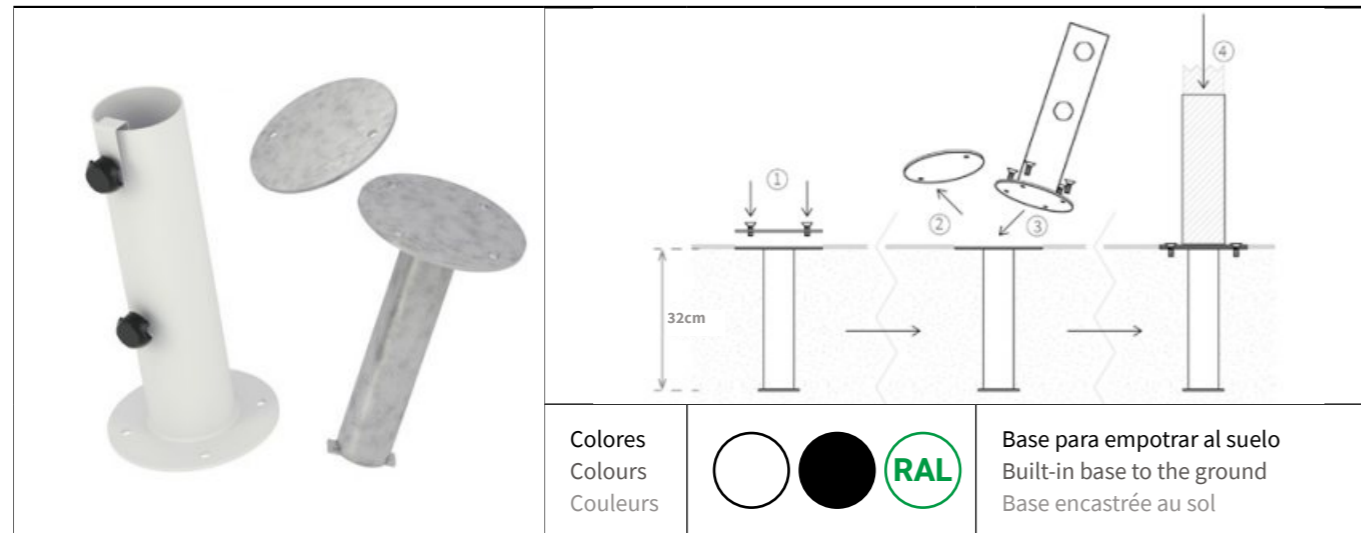

Para / For / Pour : TODAS LAS SERIES - ALL SERIES - TOUTES LES SÉRIES

Empotrar con tapa abatible / Built-in base with lid / Encastrée avec couvercle rabattable

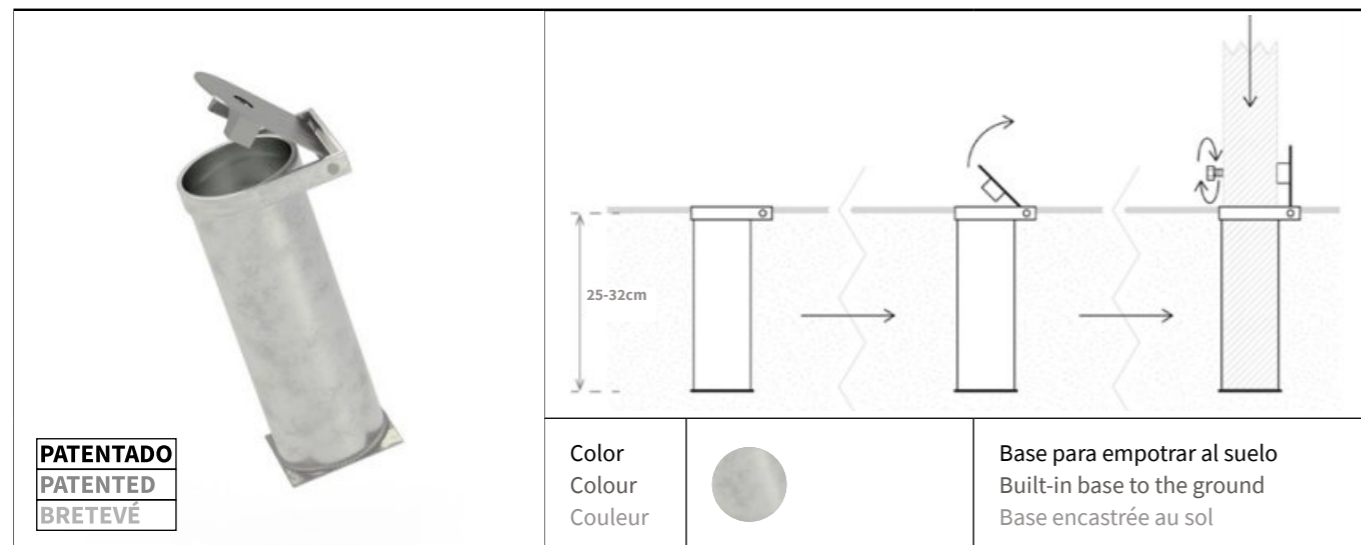

Para / For / Pour : SERIE ESTANDAR - ESTANDAR EXTRA - ELITE - PALMA - BERLIN

PATENTADO
PATENTED
BRETEVÉ

Base 4 baldosas / 4 tiles base / Base 4 delles



Para / For / Pour : TODAS LAS SERIES - ALL SERIES - TOUTES LES SÉRIES

Base 8 baldosas / 8 tiles base / Base 8 delles



Para / For / Pour : TODAS LAS SERIES - ALL SERIES - TOUTES LES SÉRIES

Base XXL 250 / XXL 250 base / Base XXL 250



Para / For / Pour : PARASOLES > 4,5X4,5M

Iluminación

Lighting / Éclairage

Caja de conexión Connection box Boîte de jonction

Instalación eléctrica del parasol realizada en fábrica. Incluye el cableado interno del mástil y una caja con 4 conexiones 220V

The parasol's wiring is carried out in the factory. It includes the pole's internal wiring and a box with 4 220V connections.

Installation électrique du parasol réalisée en usine. Comprend le câblage interne du mât et une boîte avec 4 connexions 220V

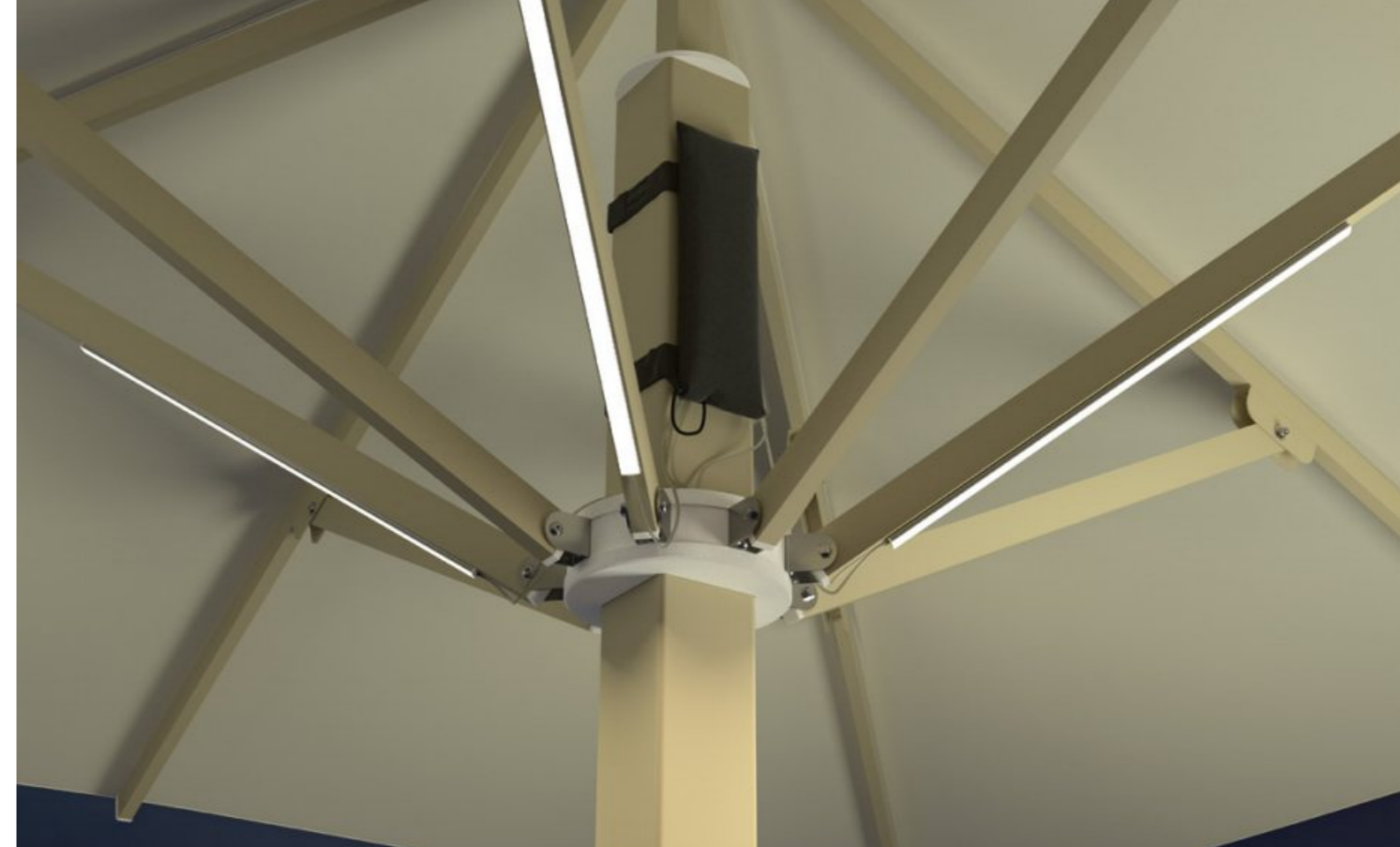

Kit tiras LED LED strips kit Kit rubans à LED

El montaje va a cargo del cliente. Kit de iluminación que incluye un enchufe, un transformador, un atenuador, un mando a distancia, una funda para guardar el transformador y el atenuador en el parasol y las 4 tiras LED a elegir entre las siguientes opciones. La funda se cuelga en las varillas o el mástil del parasol.

The assembly is at the customer's expense. The lighting kit includes a plug, a transformer, a dimmer, a remote control, a cover to keep the transformer and the dimmer in the parasol and the 4 LED strips to be chosen.

Le montage est à la charge du client. Ce kit d'éclairage comprend une prise, un transformateur, un variateur, une télécommande, un couvercle pour garder le transformateur et le variateur dans le parasol et les 4 rubans à LED au choix.

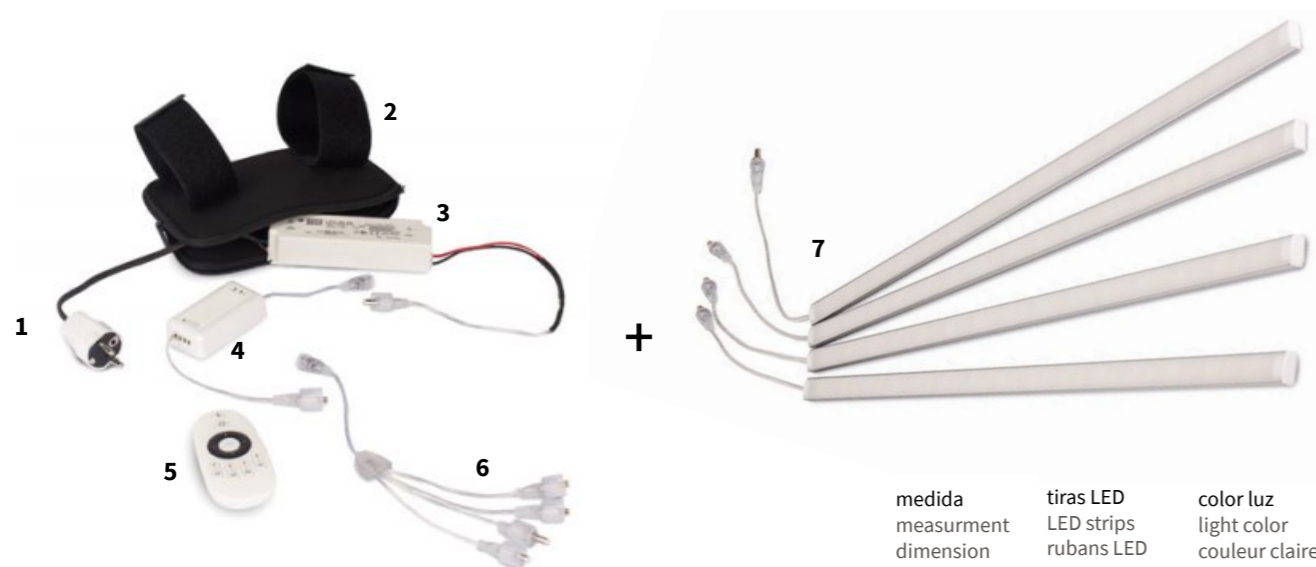

1. Enchufe / Plug / Prise
2. Funda con velcro / Cover with velcro / Couvercle velcro
3. Transformador / Transformer / Transformateur
4. Atenuador / Dimmer / Variateur
5. Mando a distancia / Remote control / Télécommande
6. Distribuidor / Distributor / Distributeur
7. Tiras LED / LED strips / Rubans à LED

medida measurement dimension	tiras LED LED strips rubans LED	color luz light color couleur claire
50cm	4	2700K
100cm	4	2700K
50cm	4	RGB
100cm	4	RGB

Kit LED con batería LED kit with battery Kit LED avec batterie

El montaje va a cargo del cliente. Kit de iluminación que incluye batería, funda para la batería, un atenuador, un mando a distancia, un cargador para la batería y las 4 tiras LED. La funda se cuelga en las varillas o el mástil del parasol.

The assembly is at the customer's expense. The lighting kit includes a battery, a battery case, a dimmer, a remote control, a charger for the battery and the 4 LED strips. The case hangs on the ribs or the parasol's pole.

Le montage est à la charge du client. Le kit d'éclairage comprend une batterie, un boîtier de batterie, un variateur, une télécommande, un couvercle pour maintenir la batterie et le variateur dans le parasol et les 4 bandes LED.



1. Cargador batería 12V / Battery charger 12V / Chargeur de batterie 12V
2. Funda con velcro IP54 / Cover with velcro IP54 / Couvercle velcro IP54
3. Batería 10Ah / Battery 10Ah / Batterie 10Ah
4. Atenuador / Dimmer / Variateur
5. Mando a distancia / Remote control / Télécommande
6. Distribuidor / Distributor / Distributeur
7. Tiras LED IP65 / LED strips IP65 / Rubans à LED IP65

Iluminación

Lighting / Éclairage



Sistema de luz LED integrada

Built-in connection box

Boîte de jonction intégrée

Instalación eléctrica del parasol realizada en fábrica. Incluye el cableado interno del mástil, una caja con 2 conexiones, un interruptor, un mando y 4 tiras led a elegir entre las siguientes opciones:

The parasol's wiring is carried out in the factory. It includes the pole's internal wiring, a box with 2 connections, a switch, a remote control and 4 LED strips to choose from the following options:

Installation électrique du parasol réalisée en usine. Comprend le câblage interne du mât, une boîte avec 2 connexions, un interrupteur, une télécommande et 4 rubans à LED à choisir parmi les options suivantes:



Caja de conexión
Connection box
Boîte de jonction

2 conexiones de 220V
4 conectores para tiras LED

2 220V connections
4 connectors for LED strips

2 connexions 220V
4 connecteurs pour bandes LED



Mando a distancia
Remote control
Télécommande



Tiras LED
LED strips
Rubans à LED

medida measurement dimension	tiras LED LED strips rubans à LED	color luz light color couleur claire
50cm	4	2700K
100cm	4	2700K
50cm	4	RGB
100cm	4	RGB

Calefacción infrarojos

Infrared heating / Chauffage infrarouge

Los calefactores infrarrojos son eficientes en energía porque no calientan el aire, sino que proporcionan calor a las personas que están cerca.
Colocación debajo de las horquillas del parasol.

Infrared heaters are energy efficient as heat is projected directly to people around it, which makes heating the air unnecessary.
Fitting at the support rib.

Le chauffage infrarouge est économe en énergie parce qu'il ne chauffe pas l'air, mais il fournit de la chaleur à ceux autour.
Disposition aux côtes de parasol.



potencia power puissance	1,5 kw
--------------------------------	--------

protección protection protection	IP155
--	-------

cobertura coverage couverture	11m2
-------------------------------------	------

medidas measures mesures	48x12x12cm
--------------------------------	------------

peso weight poids	1,7 kg
-------------------------	--------

colores colors couleur	Blanco/Negro White/Black Blanc/Noir
------------------------------	---



Fundas

Case / Housses

Tejido
Fabric
Tissu



Polisilk
200 g/m2
ref. TOP

Acrílico
300 g/m2
ref. TAS

PVC
400 g/m2
ref. TPS

Para la serie:
For serie:
Pour série:

Estandar
Estandar Extra
Elite
Elite Telescópico
Elite Plus
Elite Desplazado
Palma
Palma Desplazado
Berlin
Berlin Desplazado
Luxe



Funda protectora simple
Simple protection case
Housse protection simple

Recomendado para parasoles hasta 3x3m
Recommended for parasols to 3x3m
Recommandée pour parasol jusqu'à 3x3m

Para la serie:
For serie:
Pour série:

Estandar
Niza
Classic
Gold extra
Basic
Street



Cerramientos laterales

Side screens / Bâches latérales

Instalación en las varillas del parasol.
Installation on parasol ribs.
Installation sur les baleines.

Tejido a juego con la cubierta del parasol.
Same fabric as parasol.
Tissu assorti à la couverture du parasol.

Ventana en PVC transparente lisa.
Windows in transparent PVC.
Fenêtre en PVC transparent.

Se suministra montado en las guías de aluminio y con todos los accesorios incluidos para la instalación.
Supplied in aluminum guides with all accessories for installation included.
Fournie déjà montée sur les rails en aluminium et avec tous les accessoires inclus pour l'installation.

Opcional canaletas vierteaguas para unir los parasoles.
Optional gutters to join parasols.
Optionnel gouttières pour joindre les parasols.

Opcional puntales de refuerzo.
Optional reinforcement struts.
Optionnel étais de force.

Los cerramientos dan un peso extra a las varillas de los parasoles, recomendamos el uso de puntales de refuerzo para asegurar la estabilidad de los parasoles.
No se aconseja instalar cerramientos en todos los lados de los parasoles. Los parasoles no están fabricados para dejar los cerramientos permanentemente instalados y tampoco para utilizar como una estructura fija tipo carpa.

The side screens give extra weight to the ribs of the parasols, we recommend the use of reinforcement struts to ensure the stability of the parasols.
It is not advisable to install side screens on all sides of the parasol. The parasols are not manufactured to leave side screens permanently installed and are not intended to be used as a fixed tent type structure.

Puisque les bâches ajoutent un poids supplémentaire aux baleines du parasol, nous recommandons l'utilisation des étais de force pour assurer la stabilité des parasols.
Il n'est pas conseillé d'installer des bâches sur tous les côtés des parasols. Les parasols ne sont pas fabriqués pour y laisser les boîtiers installés de façon permanente et ne sont pas conçus pour être utilisés comme une structure fixe de type tente.

Instalaciones / Installations / Les installations

Los parasoles se unen mediante canaletas vierteaguas y los cerramientos laterales mediante solapas con velcro.

Parasols are joined by rain gutters and the side screens by velcro flaps.

Les parasols sont reliés par des gouttières et les bâches latérales par des rabats en velcro.

Los volantes inferiores tienen que sobrar para salvar irregularidades del terreno si conviene.

The lower valance have to be left to save irregularities of the terrain if appropriate.

Les volants inférieurs doivent être laissés pour sauvegarder les irrégularités du terrain, le cas échéant.

Se pueden fabricar medidas especiales para adecuarlos a la instalación que precise.

We manufacture special measures to adapt them to the installation you need.

Nous fabriquons des mesures spéciales pour les adapter à l'installation dont vous avez besoin.

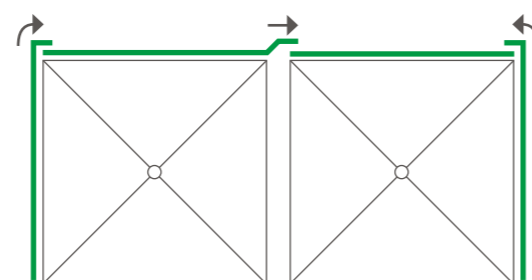
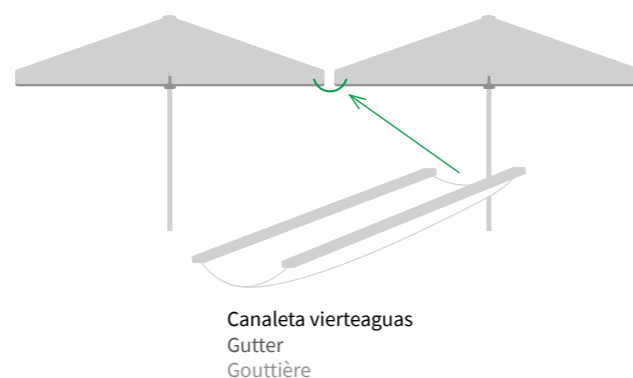

Ejemplo de instalación (vista superior)
Installation example (top view)
Exemple d'installation (vue de dessus)

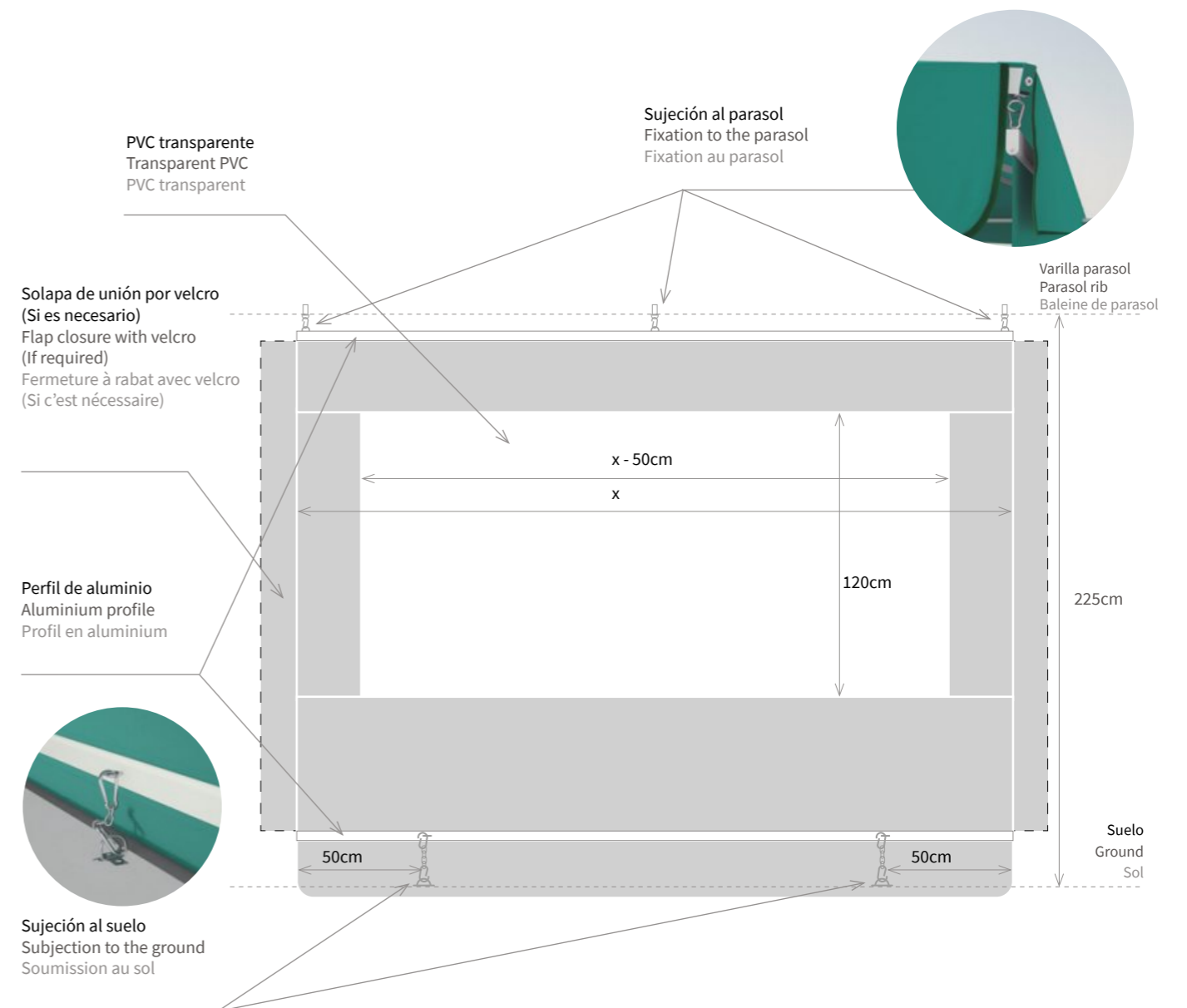

Separadores

Fences / Séparateurs

Textiles

Base peana de acero inoxidable de 7,5kg y ø36cm.
Mástil de acero inoxidable de 75cm de altura y ø5cm.
Barras de acero inoxidable con clips de sujeción.

Stainless steel base of 7,5kg and ø36cm.
Pole of 75cm high and ø5cm in stainless steel.
Stainless steel cross beams with clips.

Base en acier inoxydable de 7,5kg et ø36cm.
Mât en acier inoxydable de ø5cm et une hauteur de 75cm.
Barres en acier inoxydable avec crochets.

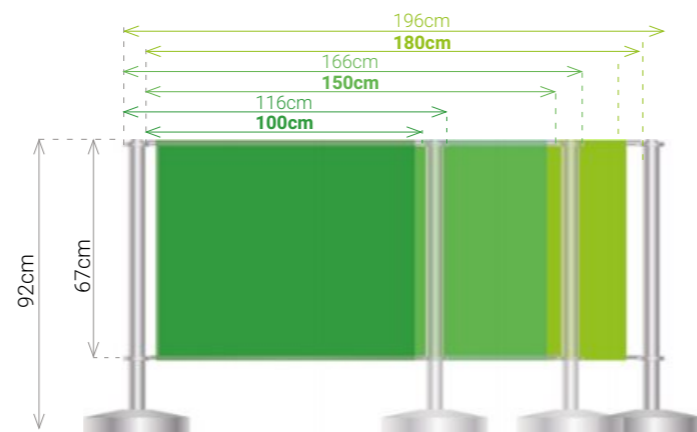
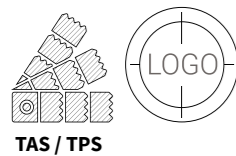

Maceteros / Planter / Planteur

Fabricados en chapa de acero de 1,5mm.
Acabados con pintura oxiron color gris oscuro.
Cristal laminado de 4+4mm.
Guías para el cristal de 15x15x1,5mm.
Sistema de desagüe.
Pies de soporte para fijar al suelo..

Made of 1,5mm steel sheet.
Dark gray finish with oxiron paint.
4+4mm laminated glass.
15x15x1,5mm guides for glass.
Drainage system.
Support for ground fixing.

Fait en tôle d'acier de 1,5mm.
Peinture oxiron gris foncé.
Verre feuilleté 4+4.
Rails pour verre de 15x15x1,5mm.
Système de drainage.
Support pour fixer au sol.

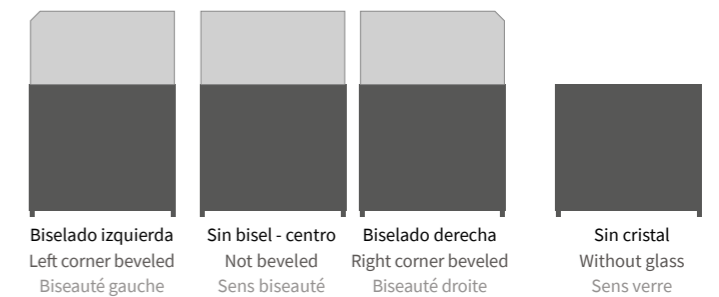
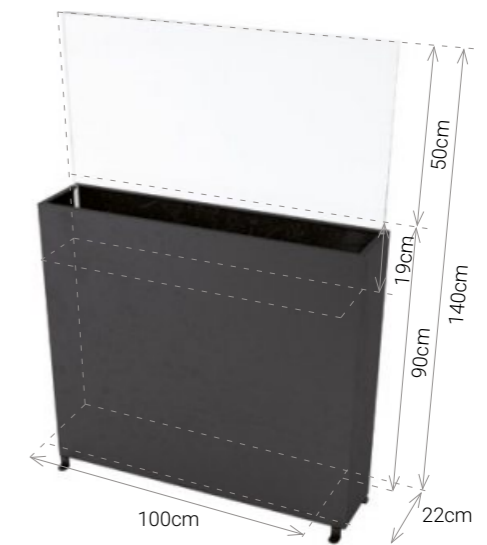

Estructura

Frame / Monture

Acabado color sólido Solid color finish Finissage an couleur solide

Elija entre mas de 200 colores para el acabado de la montura. (Consulte carta de colores RAL). Este acabado está disponible solo para las monturas de aluminio y tiene un incremento sobre el precio de tarifa del parasol.

Choose from a variety of more than 200 colors for the frames. (Consult RAL colors). Frame colors are only available for aluminium frames. Surcharge indicated on price list.

Choisissez entre plus de 200 couleurs pour la structure. (Consulte la carte RAL).Les couleurs pour la structure sont seulement disponibles pour les structures en aluminium. Coût supplémentaire indiqué dans la liste de prix.



Para la serie:
For serie:
Pour série:

- | | |
|-------------------|-------------------|
| Estandar | Elite Plus |
| Estandar Extra | Berlín |
| Elite | Berlín desplazado |
| Elite telescopico | Palma |
| Elite desplazado | Palma desplazado |

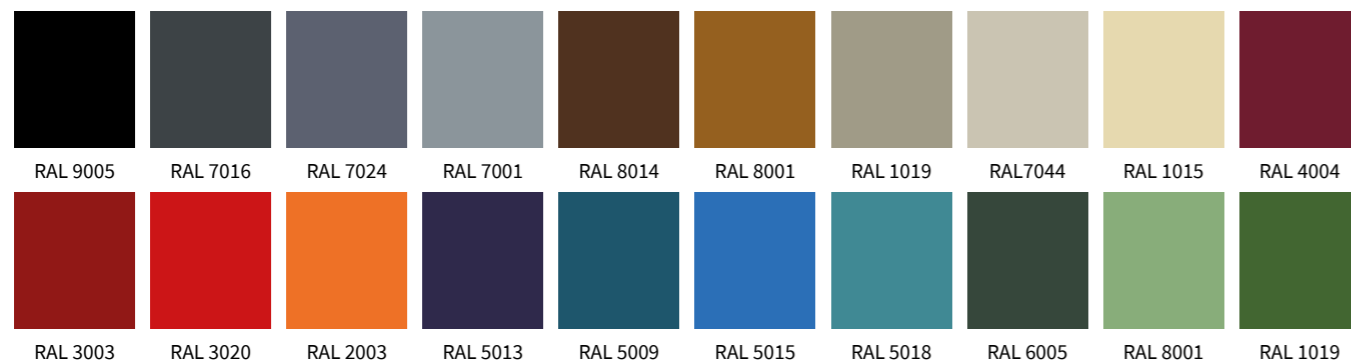

Acabado imitación madera Wood-like finish Finissage imitation bois

Acabado de alta calidad con textura y color imitación madera. Este acabado tiene las mismas cualidades, resistencia y durabilidad del aluminio y la estética, textura y color de la madera.

High quality finish with wood imitation feel and color. Same strength and durability as aluminium but natural wood looking.

Finition de haute qualité avec texture et couleur imitation bois. Mêmes propriétés, résistance et durabilité que l'aluminium mais avec l'apparence du bois.



Para la serie:
For serie:
Pour série:

- | |
|-------------------|
| Estandar Extra |
| Elite |
| Elite Telescopico |
| Elite Plus |
| Elite Desplazado |
| Palma |
| Palma desplazado |

Estampación textil

Textile printing / Estampage textile

Diseñamos o preparamos vuestra propuesta para la estampación textil en los parasoles. Una vez aprobada la propuesta en soporte digital procededemos con la estampación.

We design or prepare your ideas for the textile printing. Once you approve the proposal in a digital format, we start to print.

Nous concevons ou préparons vos idées pour l'estampage textile sur les parasols. Une fois adoptée votre idée sur support numérique, nous procédons à l'estampage.

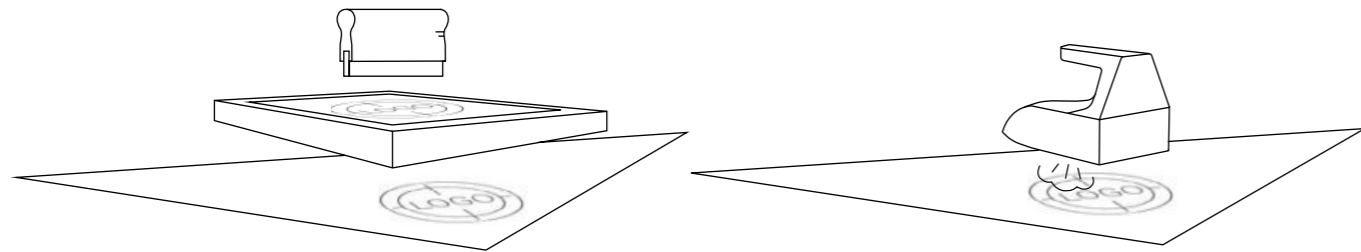
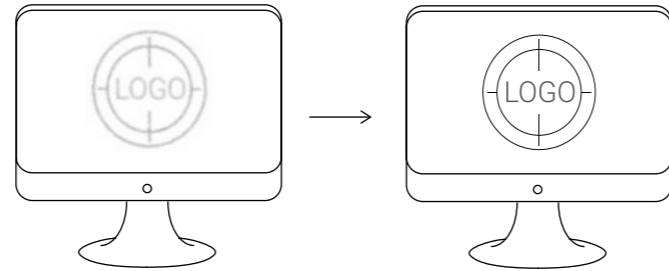

Serigrafía Silk-screen Sérigraphie

- Se aplica a cualquier tejido.
- Por cada color se utiliza un fotolito y una estampación.
- Máximo 3 tintas.
- It applies to any fabric.
- For each color we use a photolith and a print.
- Maximum 3 inks.
- Applicable à quelconque tissu.
- Pour chaque couleur on utilise un typon et un estampage.
- Maximum 3 encres.

Vinilo textil Textile vinyl Vinyle textile

- Sólo tejido acrílico.
- 1 solo color o CMYK.
- De 1 a 8 estampaciones.
- Medidas hasta 95 x 75cm.
- Only acrylic fabric.
- Only 1 color or CMYK.
- From 1 to 8 prints.
- Measures up to 95 x 75cm.
- Seulement tissu acrylique.
- 1 seule couleur ou CMYK.
- De 1 à 8 estampages.
- Mesures jusqu'à 95 x 75cm.

Faldón luminoso

Lighting volant / Volant lumineux

Con el faldón luminoso, su logo será el más vistoso, sobre todo por la noche. Funciona con una placa de tecnología LED muy fina y ligera insertada en el faldón y un transformador de 24V que le permite un buen flujo lumínico para que sea visible a cortas y largas distancias. Para cerrar el parasol hay que quitar el faldón, que se monta fácilmente con velcro.

The luminous volant will make your logo visible and attractive, especially at night. We use a very thin and light LED technology plate inserted into the volant with a 24V transformer that will allow a good light flow so that the logo will be visible at short and long distance. To close the parasol you have to remove the volant, which is easily mounted with Velcro.

Le volant lumineux rendra votre logo visible et attractif, surtout la nuit. Nous utilisons une plaque de technologie LED très fine et légère insérée dans le volant avec un transformateur 24V qui permet un bon flux lumineux afin que le logo soit visible à courte et longue distance. Pour fermer le parasol, vous devez retirer le volant, qui se monte facilement avec du velcro.

Rotulación hasta 2 metros de largo
Lettering up to 2 metres long
Lettrage jusqu'à 2 mètres de long

Para la serie:
For serie:
Pour série:

- Estandar Extra
- Elite
- Elite Telescopico
- Elite Plus
- Elite desplazado
- Palma
- Palma desplazado
- Berlin
- Berlin desplazado



Tejidos

Fabric / Tissu

✓ Basicos

No se aplica ningún incremento en el precio.
No price increase applied.
Aucune augmentation de prix appliquée.

Poli-cot

ref TPA - 180g/m²

Composición 30% poliéster / 70% algodón.
Evita la formación de malos olores y previene el crecimiento de hongos y no provoca reacciones alérgicas. Al presentar un alto porcentaje de algodón, fibra natural, absorbe el calor con mayor eficacia que los tejidos sintéticos.



Crudo

Composition 30% polyester / 70% cotton.
It prevents the formation of bad odors and prevents the growth of fungi and does not cause allergic reactions. It absorbs heat more effectively than synthetic fabrics because have a natural fiber.

Composition 30% polyester / 70% coton.
Il empêche la formation de mauvaises odeurs et empêche la croissance de champignons et ne provoque pas de réactions allergiques.
En présentant un pourcentage élevé de coton, de fibres naturelles, il absorbe la chaleur plus efficacement que les tissus synthétiques.

Lona

ref TOP - 200g/m²

Alta solidez de colores/Resistencia a las manchas/ 100% Producido en Europa/Eco friendly/100% Reciclable/Protección máxima de la piel/ Bloquea más del 97% de los UV. Los colores que NO BASICOS tienen un metraje mínimo por pedido.

High colour fastness/Resistance to stains/ 100% Produced in Europe/Eco friendly/ 100% Recyclable/Maximum skin protection/ Blocks over 97% of UV. NON-BASIC colors have a minimum length per order.

Grande solidité des couleurs/Résistance aux taches/100% Produit en Europe/Écologique/ 100% Recyclable/Protection maximale de la peau/Bloque plus de 97% des UV. Les couleurs NON BASIC ont une longueur minimale par commande.



REPELENTE AL AGUA
WATER-REPELLENT
HYDROFUGE

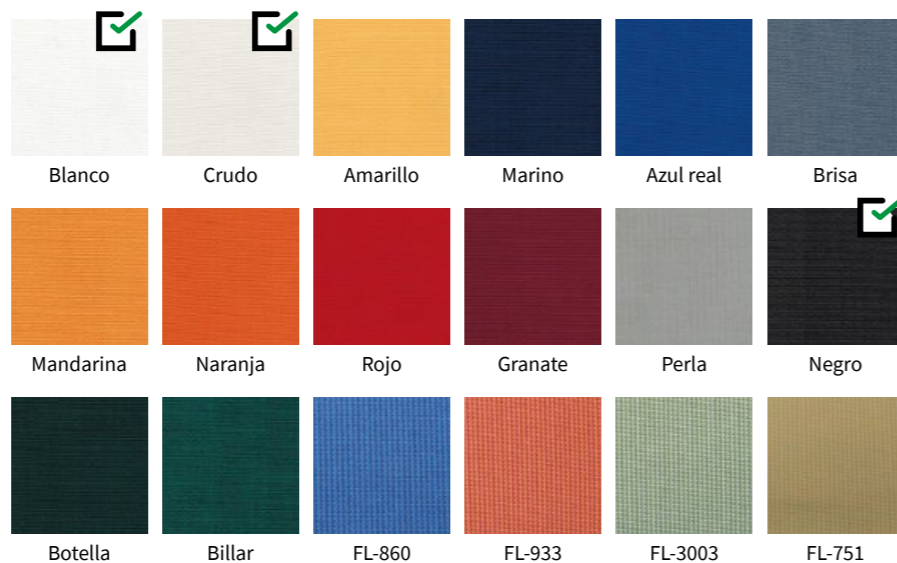

PVC Port

ref TPS - 400g/m²

Larga vida/ Elevada resistencia frente a los rayos UV/ Colores sólidos/ Máxima estabilidad/ Impermeabilidad/ Tratamiento antihongos para entornos marinos/ Fácil limpieza, manejo y mantenimiento.

Long life/High UV resistance/Solid colours/ Maximum stability/Waterproof/Anti-fungal treatment for marine environments/Easy cleaning, handling and maintenance.

Longue durée de vie/Haute résistance aux UV/ Couleurs solides/Stabilité maximale/ Imperméable/Traitement antifongique pour environnements marins/Nettoyage, manipulation et entretien faciles.



IMPERMEABLE
WATERPROFF
IMPERMÉABLE



PVC PORT M1

ref TPS - 470g/m²

Larga vida/ Elevada resistencia frente a los rayos UV/ Colores sólidos/ Máxima estabilidad/ Impermeabilidad/ Tejido ignífugo con certificado Fire Retardant/ Fácil limpieza, manejo y mantenimiento.

Long life/High UV resistance/Solid colours/ Maximum stability/Waterproof/ Fire retardant fabric with Fire Retardant certificate / Easy cleaning, handling and maintenance.

Longue durée de vie/Haute résistance aux UV/ Couleurs solides/Stabilité maximale/ Imperméable/ Tissu ignifuge avec certificat ignifuge / Nettoyage, manipulation et entretien faciles.



IMPERMEABLE
WATERPROFF
IMPERMÉABLE



IGNIFUGO
FIREPROFF
IGNIFUGER



PVC Screen

ref TSS 530g/m²

Gran protección térmica / Transpirable / Tejido ignífugo con certificado Flame Retardant M1 / No es impermeable.

Great thermal protection / Breathable / Fire retardant fabric with Fire Retardant certificate / Is not waterproof.

Excellente protection thermique / Respirant / Tissu ignifuge avec certificat ignifuge / N'est pas étanche.



TRANSPIRABLE
BREATHABLE
RESPIRANT



IGNIFUGO
FIREPROFF
IGNIFUGER



Tejidos

Fabric / Tissu

Acrilico / Acrylic / Acrylique

ref **TAS** - 300g/m²

Rápido secado/Transpirante/Columna de agua de 300/Repelente al agua/Máxima resistencia/Antibacteriano/Anti-manchas/Anti-UVI/Doble cara/Producción respetuosa/Fácil mantenimiento.

Fast drying/Breathable/Water column 300/Water repellent/Maximum resistance/Anti-bacterial/Anti-stain/Anti-UVI/Double-sided/Respectful production/Easy maintenance.

Séchage rapide/Respirant/Colonne d'eau 300/Hydrofuge/Résistance maximale/Anti-Bactérien/Anti-Taches/Anti-UVI/Double face/Production respectueuse/Entretien facile.



REPELENTE AL AGUA
WATER-REPELLENT
HYDROFUGE

Basicos

No se aplica ningún incremento en el precio.
No price increase applied.
Aucune augmentation de prix appliquée.

Resinado / Resin coat / Resiné

Posibilidad de acabado impermeable.
Columna de agua 1000.
Addition waterproof finish.
Water column 1000.
Finition imperméable complémentaire.
Colonne d'eau 1000.

Green®

Tejido Green® (by Sauleda & Pureti). Los tejidos tratados con este acabado limpian y purifican el aire mediante la fotocatalisis, eliminando contaminantes como NOx, SOx y COVs. Los tejidos Green® tienen además un efecto autolimpiante y de reducción de los mohos.

Green® fabric (by Sauleda & Pureti). With this treatment, fabrics will clean and purify the air through photocatalysis, removing contaminants such as NOx, SOx and VOCs. Green® fabrics also have a self-cleaning and mold-reducing effect.

Tissu Green® (par Sauleda & Pureti). Avec ce traitement, les tissus nettoient et purifient l'air par photocatalyse, éliminant les contaminants tels que les NOx, les SOx et les COV. Les tissus Green® ont également un effet autonettoyant et réducteur de moisissure.

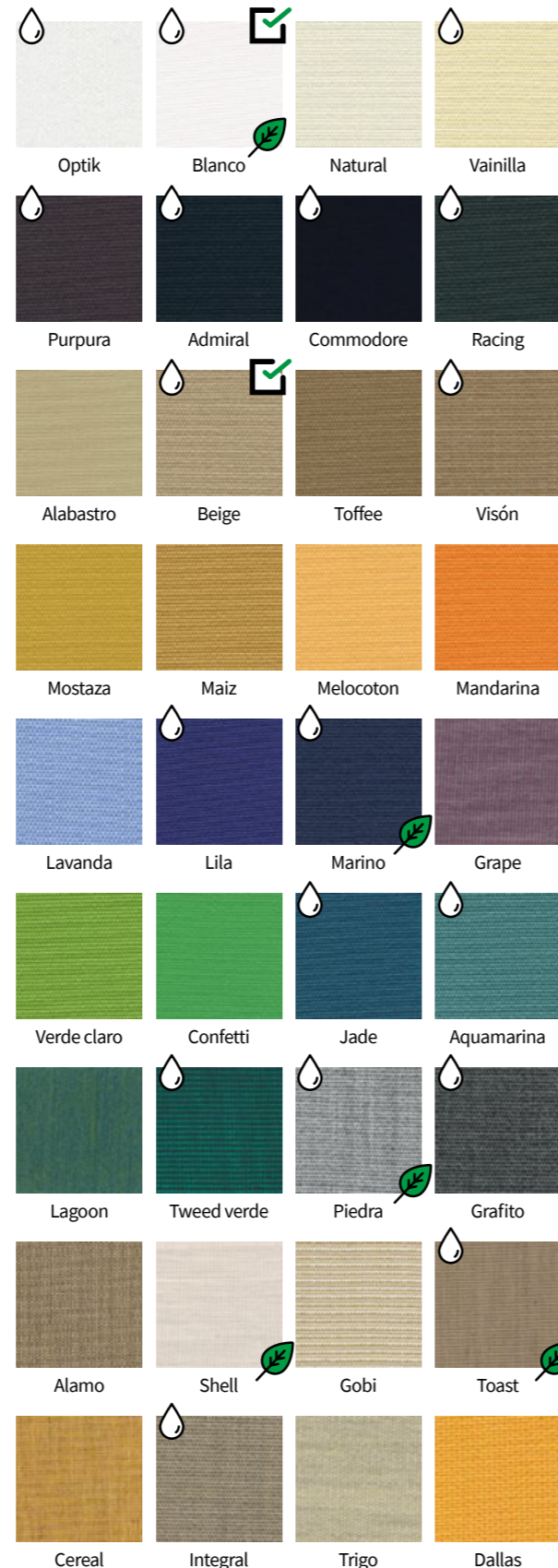

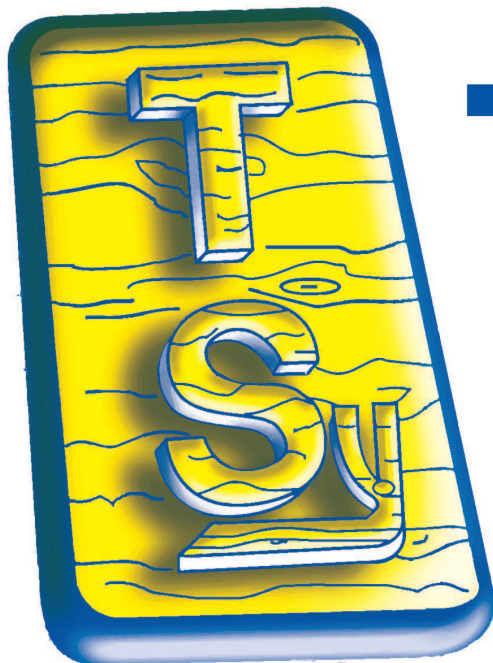

**Tecno
Soley**